

F3200/NDU
AS4428.1
INSTALLATION & CONFIGURATION MANUAL

F3200 PRODUCT MANUAL
Document Number: LT0255

Issue 1.04; 30 June 2004

-- APPROVALS --	
AUSTRALIAN STANDARD AS4428.1	
- SSL Listing Number	afp789
AUSTRALIAN STANDARD AS3548 1995 Class A	
NEW ZEALAND STANDARD NZS4512 1997	

The F3200 and NDU is manufactured by:

Tyco Safety Products
211 Maces Road
Christchurch
NEW ZEALAND

Tel: (03) 389-5096
Fax: (03) 389-5938

COPYRIGHT (C) 2001, 2004

Information contained in this document is subject to copyright, and shall not be reproduced in any form whatsoever, without the written consent of Tyco Safety Products.

Information contained in this document is believed to be accurate and reliable, however Tyco Safety Products reserves the right to change the content without prior notice.

**TYCO SAFETY PRODUCTS
END USER LIABILITY DISCLAIMER**

The F3200 Fire Indicator Panel and NDU have a configuration programming facility which may be accessed from the keypad by using a password.

This programming facility allows the user to define detail of the operation of the System is being customised. It is possible for the user to program operational features that prevent the unit from meeting statutory requirements.

Tyco Safety Products does not accept responsibility for the suitability of the functions programmed by the user.

AS3548 NOTE

This is a class A product. In a domestic environment this product may cause radio interference in which case the user may be required to take adequate measures.

TABLE OF CONTENTS

End User Liability Disclaimer	ii
Amendments	vi
CHAPTER 1 INTRODUCTION	1-1
1.1 SCOPE.....	1-2
1.2 ASSOCIATED DOCUMENTATION.....	1-3
1.3 PRODUCT HISTORY LOG.....	1-4
1.4 GLOSSARY OF ABBREVIATIONS	1-5
1.5 GLOSSARY OF TERMINOLOGY	1-6
CHAPTER 2 SYSTEM DESCRIPTION	2-1
2.1 OVERVIEW	2-2
2.2 PHYSICAL STRUCTURE.....	2-6
2.3 SYSTEM STRUCTURE	2-8
CHAPTER 3 SYSTEM SPECIFICATIONS	3-1
3.1 GENERAL.....	3-2
3.2 MECHANICAL SPECIFICATIONS.....	3-3
3.3 ELECTRICAL SPECIFICATIONS	3-4
3.4 INPUT SPECIFICATIONS	3-8
3.5 OUTPUT SPECIFICATIONS	3-15
3.6 CONTROLS	3-19
3.7 DISPLAYS	3-20
3.8 ORDERING INFORMATION	3-21
CHAPTER 4 CONFIGURING A FIP	4-1
4.1 GENERAL.....	4-2
4.2 MODULE CONFIGURATION	4-2
4.3 BATTERY & POWER SUPPLY.....	4-3
4.4 LINKS ON PCB MODULES	4-9
CHAPTER 5 INSTALLATION & WIRING	5-1
5.1 INSTALLATION	5-2
5.2 FIELD WIRING.....	5-8
5.3 AZC WIRING.....	5-10
5.4 MAF ANCILLARY RELAY WIRING	5-12
5.5 WARNING SYSTEM WIRING	5-15
5.6 MODULE RELAY WIRING	5-20
5.7 OPEN COLLECTOR WIRING	5-22
5.8 ASE INSTALLATION AND WIRING	5-24
5.9 RDU WIRING	5-25
5.10 NDU INSTALLATION AND WIRING	5-27
5.11 NZ MODE INPUTS AND OUTPUTS	5-28
5.12 INSTALLATION : NZ DISPLAY EXTENDER BOARD & BRIGADE DISPLAYS	5-30
CHAPTER 6 APPLICATIONS	6-1
6.1 AS1668 AIR CONDITIONING CONTROL	6-2
6.2 GASEOUS FIRE EXTINGUISHING	6-9
6.3 SUB FIP MONITORING.....	6-22
6.4 FIRE DETECTION IN HAZARDOUS AREAS (EXPLOSIVE ATMOSPHERES).....	6-24
6.5 USE OF NORMALLY CLOSED CONTACTS	6-33
6.6 SPECIAL CONNECTIONS TO DETECTORS.....	6-34

CHAPTER 7 ALIGNMENT, ADJUSTMENT & PLACING INTO OPERATION7-1
7.1 ALIGNMENT & ADJUSTMENT..... 7-2
7.2 PLACING INTO OPERATION 7-3
7.3 ERROR MESSAGES FOR STARTUP 7-7

APPENDIX A COMPATIBLE ACTUATING DEVICES (DETECTORS) A-1

AMENDMENTS

ISSUE	DATE	COMMENTS	ECN
1.0	07/02/01	Original. Split from LT0122 and modified for AS4428.1	
1.01	02/07/01	Pages 5-20, 6-21, 6-23, 6-25 and Appendices A-1, A-2 revised.	3190
1.02	15/08/01	Chapter 5 Installation revised and Section 6.2 Gas Flood revised. Added section 5.12, section 3.3.5.2.	3154
1.04	30/06/04	Preface, Pages 5-6, 5-15, 5-16, 5-19, Section 6.2 and Appendix A revised	3322

CHAPTER 1 INTRODUCTION

1.1

SCOPE

This manual provides information for the personnel responsible for planning, ordering, installing and configuring an F3200 Fire Alarm System or an NDU. It is assumed that such staff have been trained to plan/install fire alarm equipment and are familiar with the relevant standards.

The manual is divided into the following chapters:

- Chapter 1 Introduction: Information on this and other manuals.
 - Chapter 2 System Description: A description of the structure of the F3200 FIP.
 - Chapter 3 Specifications: A detailed specification and list of part numbers for the F3200.
 - Chapter 4 Configuring a FIP: Information on configuring a system, in particular battery and charger calculations.
 - Chapter 5 Installation & Wiring: Detail of installation and field wiring.
 - Chapter 6 Applications: Detail of configuration and wiring for specific applications.
 - Chapter 7 Alignment, Adjustment & Placing Into Operation: Detail on how to adjust an F3200 in the field and place it into operation.
- Appendix A
1. Compatible Detectors: A list of detectors which are approved for use with F3200.
 2. Detector Configuration: Detail on AZC and zone configuration for specific detector types.

1.2 ASSOCIATED DOCUMENTATION

1.2.1 PRODUCT

The following manuals for the AS4428.1-approved F3200 are available:

F3200 AS4428.1 Operator's Manual	For panels that comply with AS4428.1 LT0251 is in A4, loose leaf form. LT0250 is in A5, bound form.
F3200 Technical Manual	Provides technical information for system designers and service staff. Part number LT0121.
F3200 AS4428.1 Installation & Configuration Manual	This manual. Provides information for personnel responsible for system design, installation and commissioning. Part number LT0255.
F3200 AS4428.1 Programming Manual	Provides information for programming an F3200 and NDU. Part number LT0256.

1.2.2 STANDARDS RELATED

This manual makes reference to the following Australian and combined Standards:

AS1603.4	Automatic Fire Detection and Alarm Systems (obsolete) Part 1 - Control and Indicating Equipment.
AS4428.1	Automatic Fire Detection and Alarm Systems Part 1 - Control and Indicating Equipment.
AS/NZ1668.1	The use of Ventilation and Air-conditioning in Buildings. Part 1 - Fire and Smoke Control in Multi-compartment Buildings.
AS1670.1	Automatic Fire Detection and Alarm Systems- System Design, Installation and Commissioning.
AS1851.8	Maintenance of Fire Protection Equipment Part 8 - Automatic Fire Detection and Alarm Systems.
AS/NZ3548	Radio Interference Characteristics.
AS4214	Gaseous Fire Extinguishing Systems.

This manual makes reference to the following New Zealand standards.

NZS4512	Automatic Fire Alarm Systems in Buildings.
---------	--

1.3 PRODUCT HISTORY LOG

1.3.1 HARDWARE

<u>Part No.</u>	<u>Description</u>	<u>Iss</u>	<u>Rev</u>	<u>Date</u>	<u>Comments</u>
PA0492	8 ZONE MODULE	A	1	27/09/93	Original
		A	2	24/04/99	C31-38
PA0493	8 RELAY MODULE	A	1	10/09/93	Original
		A	2	22/09/99	C17, C18
PA0773	RS485 Comms Bd	C	4	10/04/01	Component Changes
PA0870	Controller/Display	A	1	30/01/01	Original
		B	2	Nov. 2001	Board changed, now supports flash
		B	3	Oct. 2002	Minor change
		B	4	Feb. 2003	Circuit correction
		B	5	April 2003	DFM applied
PA0873	MAF/PSU 3A	D	9	20/04/01	Original AS4428.1 Version
PA0874	MAF/PSU 6A	D	9	20/04/01	Original AS4428.1 Version

1.3.2 SOFTWARE

<u>Part No.</u>	<u>Description</u>	<u>Revision</u>	<u>Date</u>	<u>Comments</u>
SF0221	F3200 AS4428	V3.00	Feb 2001	
SF0222	F3200 AS4428 Net	V3.00	Feb 2001	
SF0224	NDU AS4428	V3.00	Feb 2001	
SF0286	F3200/NDU AS4428	V4.00	March 2003	Used in standard F3200, Networked F3200, and NDUs that have an Issue B or higher 1931-111 Controller.
SF0286	F3200/NDU AS4428	V4.01	June 2003	Fixes a problem with isolated zones.
SF0286	F3200/NDU AS4428	V4.02	July 2003	Stops charger LED flashing during battery test.

1.4 GLOSSARY OF ABBREVIATIONS

The following abbreviations are used throughout this manual:

A/C	:	Air Conditioning
ac	:	Alternating Current
AEOL	:	Active End of Line
AHr	:	Ampere Hour
ANC 1	:	Ancillary Relay 1
ASE	:	Alarm Signalling Equipment
AZC	:	Alarm Zone Circuit, or Detection Zone
AZF	:	Alarm Zone Facility, or Group (AS1603.4 terminology)
AVF	:	Alarm Verification Facility, or Check Alarm
Bd	:	Board
CIE	:	Control & Indicating Equipment
Char	:	Character
Cct	:	Circuit
COM	:	COMMON relay contact
dc	:	Direct current
EB	:	External Bell
EEPROM	:	Electrically Erasable Programmable Read Only Memory
ELV	:	Extra Low Voltage
EOL	:	End Of Line (device)
EOLR	:	End of Line Resistor
Expn	:	Expansion
E2	:	Electrically Erasable Programmable Read Only Memory
FF	:	Firefighter Facility (part of Display/Keyboard)
FIP	:	Fire Indicator Panel
FRC	:	Flat Ribbon Cable
I/O	:	Input/Output
LCD	:	Liquid Crystal Display
LED	:	Light Emitting Diode
MAF	:	Master Alarm Facility
Max	:	Maximum
Min	:	Minimum
MCP	:	Manual Call Point (Break Glass Switch)
MOV	:	Metal Oxide Varistor (Used for electrical Surge Protection)
msec	:	Millisecond
NC	:	Normally Closed
NDU	:	Network Display Unit
NO	:	Normally Open
No	:	Number
Nom	:	Nominal
PC	:	Personal Computer (small computer)
PCB	:	Printed Circuit Board
PSU	:	Power Supply Unit
PTC	:	Positive Temperature Co-efficient (Thermistor)
R1	:	Module Relay Number 1 (program abbreviation)
RL1	:	Module Relay Number 1 (text abbreviation)
RAD	:	Return Air Duct (Air Conditioning Plant)
RDU	:	Remote Display Unit
RMS	:	Root Mean Square
Reqd	:	Required
RTC	:	Real Time Clock
SAD	:	Supply Air Duct (Air Conditioning Plant)
SID	:	System Identification Number (Network device)
sq mm	:	square millimetre

GLOSSARY OF ABBREVIATIONS (CONTINUED)

T1	:	Programmable Timer Number 1 (program abbreviation)
Tmnl	:	Terminal
V1	:	Programmable Variable Number 1
VA	:	Volts Amperes
VB	:	Battery Backed Voltage
VNB	:	Non Battery Backed Voltage
+VBF	:	Fused Battery-Backed Voltage
+VNBF	:	Fused Non-Battery-Backed Voltage
WS	:	Warning System
Z1	:	Zone Number 1 (program abbreviation)
Zn1	:	Zone Number 1 (text abbreviation)
8RM	:	8 Relay Module
8ZM	:	8 Zone Module

1.5 GLOSSARY OF TERMINOLOGY

The following terminology is used throughout this manual:

Ancillary Equipment	:	Equipment external to Fire Alarm system
Ancillary Relay	:	Relay to switch external equipment
Auxiliary Output	:	Output for driving additional LEDs/relays
Baud	:	Bits per second
Control Output	:	Output from FIP to other equipment
Default	:	Pre-programming option or logic equation i.e. one that exists without the user configuring or programming it.
Detector	:	Alarm Detection Device (electrical transducer)
In Situ Test	:	Mode allowing one person to test detectors
Monitoring Service	:	Fire Brigade Authority, or any other authority which receives the FIP alarm signals.
Mapping	:	Programmable causal relationship between inputs and outputs
Zone	:	Fire searchable area of building represented by a unique number and name in the FIP, and associated with the AZC of the same number.

CHAPTER 2

SYSTEM DESCRIPTION

2.1 OVERVIEW

2.1.1 GENERAL

The F3200 is a self-contained, modular, intelligent Fire Indicator Panel (FIP) which performs the functions of the Control and Indicating Equipment (CIE) as specified by the Australian Standard AS4428.1.

It has a high degree of flexibility and expandability, catering for medium to very large buildings from 8 zones or less, to 64 zones maximum. Refer to the constraints specified in Section 3.1.3. More panels and zones can be added through the use of the Panel-link Network and the appropriate networkable F3200s.

An NDU (Network Display Unit) is essentially a networked F3200 that doesn't have any alarm zone or relay modules, but displays information received from other FIPs on the network. A number of versions are available. Some in larger cabinets have their own MAF/PSU and battery, while other slim-line versions have just the Operator Display (and Controller) and require power from a FIP (or similarly monitored and battery backed source). An NDU may be programmed to operate in either Australian (default) or New Zealand Mode.

2.1.2 DETECTOR CIRCUITS

The F3200 detector interface electronics caters for a wide range of detectors, including various types which have high alarm current requirements. A full range of compatible detectors is listed in Appendix A. F3200 also caters for interfacing to:

- Intrinsically safe circuit barriers/isolators (hazardous areas);
- Long line circuits e.g. from a sub-indicator FIP;
- Tamper-proof circuits e.g. for water valve supervision.

2.1.3 DISPLAYS

The primary display of the F3200 is a 2 line by 40 character LCD on which the status messages and prompts are shown. The LCD has backlight illumination which is turned on when there is an alarm or operator interaction. Common conditions are displayed on 9 LEDs adjacent to the LCD.

The display panel composed of the LCD, common LEDs and keypad is called the Operator Display panel. The portion within the red border is called the Firefighter's Facility (FF). It includes the common status LEDs for ALARM, ISOLATED and FAULT. As an optional extra, individual zone status (ALARM, ISOLATE and FAULT) can be displayed on LEDs by fitting the appropriate number of 16 Zone LED Display boards. By default Zone 1 corresponds to the top row of LEDs (3) on the left most display, Zone 2 to the row below it, etc, (top to bottom, left to right). Display Bds may also annunciate Relay status. Alarm LED on = relay energised, Isolated LED on = relay isolated, Fault LED on = relay wiring fault (i.e. supervision fault). The relay LEDs simply follow the zone LEDs in the same order that they occur in the FIP. For example, a system with 3 x 8 Zone Modules, 2 x 8 Relay Modules, would require 3 Display Bds. Relay 1 will be annunciated on the 25th row of LEDs and the last 8 rows will be unused. Mapping zones and relays to LEDs in other patterns is programmable.

The F3200 electronics includes, as standard, an open collector transistor output for each zone which can be used to drive an internal or remote mimic display.

An NDU in New Zealand mode may have an additional 3 system status indicators on the NZ Display Extender board fitted. This provides the Fire, Defect, Normal LEDs, and also connects to a Termination Bd which accepts the NZ specific inputs and outputs including the Trail Evac and Silence Alarms key-switches.

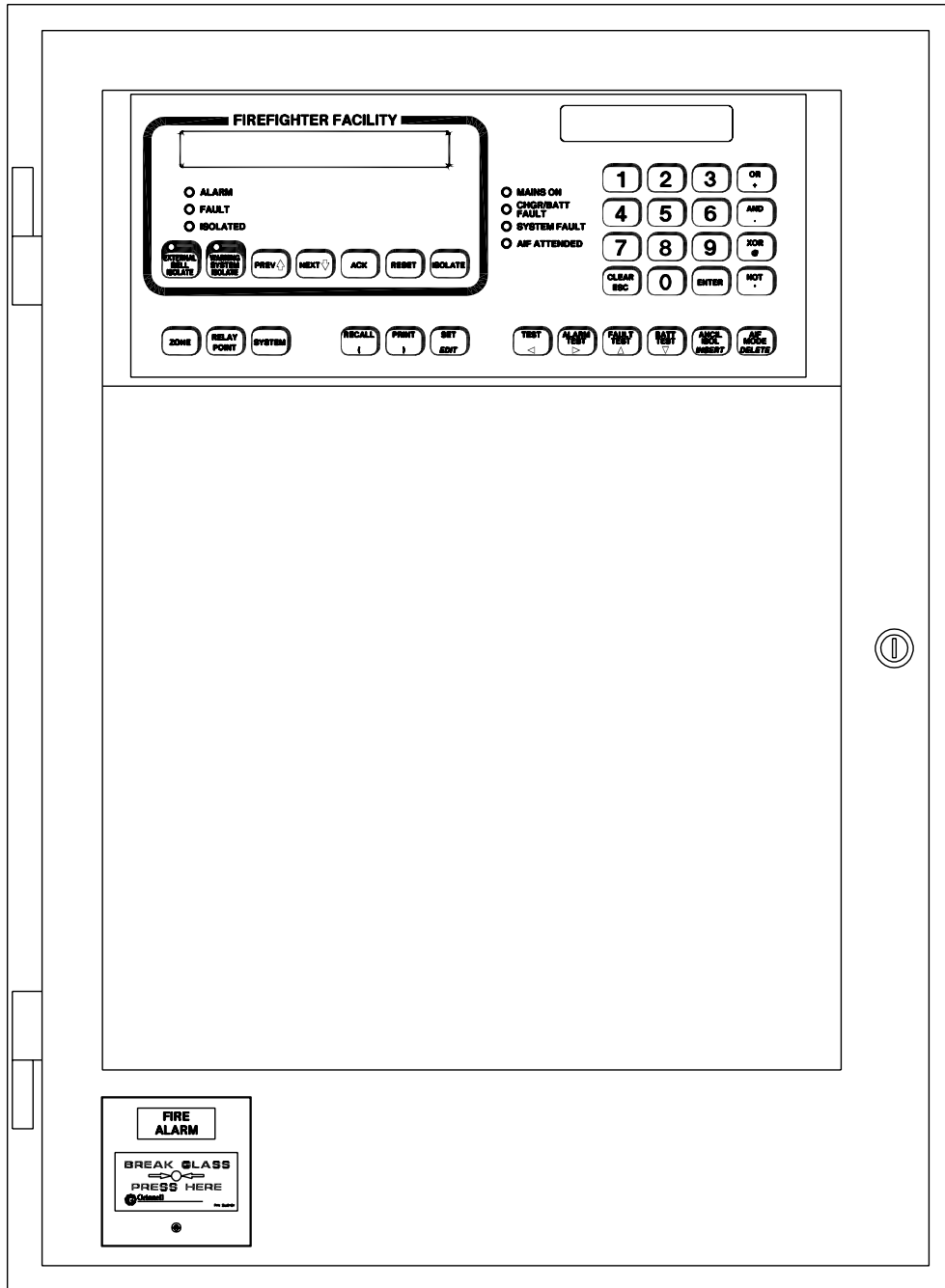

FIG 2.1.1
F3200 STANDARD CABINET - FRONT VIEW

2.1.4 OUTPUTS

The F3200 MAF/PSU Module provides 7 relays as standard. These are used for signalling to the Brigade (Monitoring Service) and for switching the External Bell, Warning System and ancillary equipment such as door holders, air-conditioning shutdown, etc.

When more than 7 relays are required, additional sets of 8 can be added by fitting 8 Relay Modules.

All outputs, including the open collectors on the 8 Zone Modules, are individually programmable by a logic equation of zone and FIP status. The default configuration (link setting and programming) dedicates 4 of the 7 relays (Alarm, Isolated, Fault and Standby, commonly called the MAF relays) to interface to the ASE (Alarm Signalling Equipment), 1 (labelled Anc2) to drive the External Bell (EB), and 1 (labelled Anc3/Bells) to drive the Warning System (WS). The MAF Standby relay has electronics which forces it to de-energise at the Battery Very Low voltage, and this must be considered if using it for any function other than its default one.

2.1.5 POWER SUPPLY

The F3200 has a 3 Amp battery charger/power supply as standard. There is adequate room for large batteries. Versions are available that have a 6 Amp PSU.

2.1.6 REMOTE DISPLAYS & PRINTER

A serial port is included in the F3200 and NDU to provide a 3 or 4 wire link to up to 8 Remote Display Units (RDU). Several versions of RDU are available.

The most commonly used versions have small, slimline cabinets (flush and surface mounting) not much larger than the F3200 display-keyboard which is fitted on them. They receive power from the F3200 FIP or NDU. Other versions look like an F3200 FIP, have their own power supply, and may have LED Display Boards fitted to them.

Additional mimic-only devices can be connected to the RDU output to monitor the F3200 zone status. For example, IO-NET can be used to provide floor mimic panels, AS1668 interfaces or remote outputs for evacuation panels.

For a networked system, an RDU can display (and control) only the zones and relays of the FIP to which the RDU is connected. With appropriate programming, such an RDU could be used to isolate the Warning System of that FIP, and hence isolate the Warning System across the entire network.

2.1.7 LOGGING PRINTER

A serial printer may be connected to the F3200 or NDU to provide a log of events and operator actions, and also to print the programmed database.

Events which are printed include:

- (i) Zone Events, e.g. Alarm, Fault;
- (ii) Zone Commands, e.g. Reset, Isolate;
- (iii) System events, e.g. communication failures, battery faults, etc.

The printout includes the time and date, the cause of the event (e.g. Zone, Relay, RDU or FIP), and the event type. Events and commands for zones and relays that have a text name programmed also have the name printed. F3200 is able to store at least 100 events for printing, being the first 100 events to occur.

As events are printed, more events are able to be put into the list. If events cannot be put into the list because it is full, the FIP keeps a count of those events it has had to discard.

LOGGING PRINTER (CONTINUED)

When the FIP is next able to put more events into the list, it prints out the number of events it had to discard.

For a networked system, with appropriate programming, an F3200 panel (or NDU) may print events and accumulate history for some or all of the other panels on the network.

2.1.8 NETWORKING CAPABILITIES

A number of F3200 fire panels, NDUs and other Panel-link compatible devices may be connected together to form a large distributed system. With suitable programming events may be annunciated at, and controlled from, other panels on the network. A panel (or NDU) may be set up as a main panel to provide a common monitoring service connection point with display and control of all facilities on the network.

The F3200 system supports the addition of colour graphics display and control terminals on the network. These units can be programmed to show graphical displays on zone alarm or fault conditions. The operator can use function keys or an optional touch screen to generate commands to the F3200 and thus have remote control of it.

2.1.9 GASEOUS FIRE EXTINGUISHING PANELS

A range of F3200 panels are available specially assembled and programmed for gaseous fire extinguishing applications complying with AS4214.

2.2 PHYSICAL STRUCTURE

The F3200 has a rugged, lockable painted steel cabinet, which houses 19 inch rack-mount equipment and comes in two height options (both have the same width and depth). The standard cabinet accommodates 15U total and the small cabinet accommodates 8U (where 1U = 1 3/4" = 44.5mm).

The Operator Display has a screened, polyester overlay mounted on a hinged inner door fitted to the top 4U position. The Controller/Display pcb mounts directly to the rear of this door.

Standard Cabinet

In the standard cabinet the space below the 4U Operator Display panel is covered by a blanking plate, but there is provision for mounting other equipment (e.g. a 7U hinged inner door for a mimic, or 16 Zone LED Display Bds), in place of this blanking plate.

There is provision for mounting additional equipment in the bottom 4U (e.g. an ASE rack), but this might encroach on battery space.

The outer door has a large acrylic window to allow viewing of the equipment inside.

Four versions of FIP are available in this cabinet. The FP0781 and FP0783, which cater for up to 64 zones, have a Cardframe fitted to the rear wall as shown in Fig 2.2.1. The FP0780 and FP0782 have provision (PCB stand-offs) for mounting up to three 8 way modules (i.e. 3 x 8 Zone or 8 Relay Modules) on the rear wall. All of these panels are supplied with 1 8 Zone Module fitted.

Small Cabinet

In the small cabinet, only 1U (of the 4U) below the 4U Operator Display is visible through the outer window. The gap is covered by a blanking plate (2U), which can be replaced by a bracket for mounting a limited range of equipment, e.g. a 1U ASE bracket, or a 1U 1 Zone Gas Control Panel.

A 6A PSU or a 7U LED Display door cannot be fitted.

Up to four 8 way modules can be mounted on the rear wall, but the bottom two of these share space with the batteries. Mounting arrangement and maximum capacity are shown in Fig 2.2.2.

Only one FIP is available (FP0784), and this comes with one 8 Zone Module fitted (in the top left position).

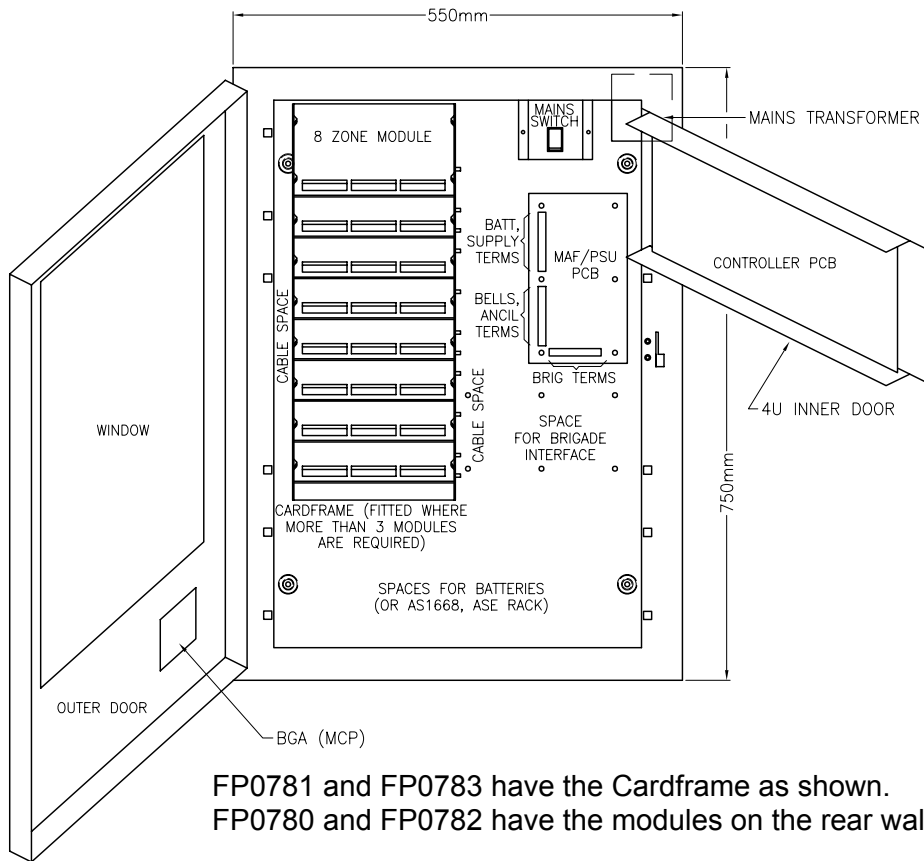

FIG 2.2.1
F3200 STANDARD CABINET WITH CARDFRAME - INTERNAL LAYOUT

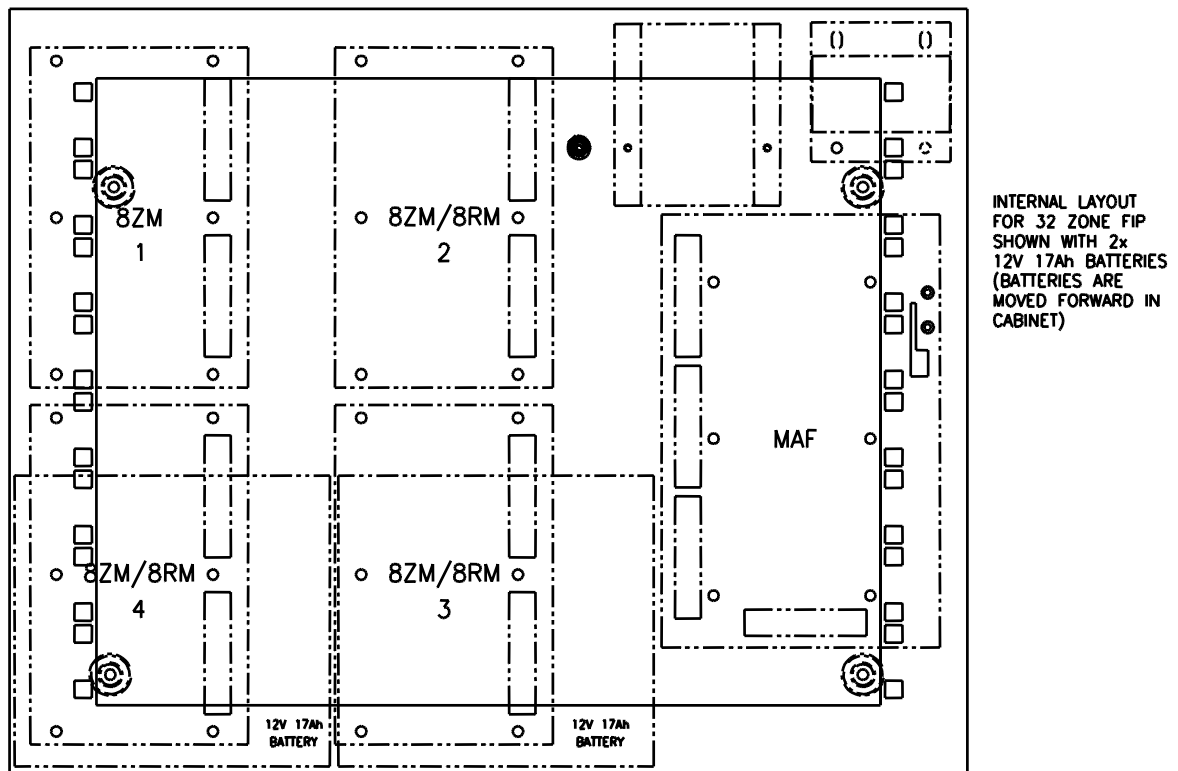

FIG 2.2.2
F3200 SMALL CABINET, MAXIMUM CONFIGURATION

2.3 SYSTEM STRUCTURE

2.3.1 PCB MODULES

The printed circuit boards which may be used in an F3200 include:

Controller/Display

Mounts on 4U inner door.

Includes: LCD, status LEDs, buzzer, and keypad connection
5Vdc supply voltage monitors for battery charger
microprocessor & memory
serial I/O bus control for all other modules
reference voltage generation for I/O modules
UARTs and serial port electronics
real time clock calendar integrated circuit
FRC connection to other modules.

MAF/PSU

Mounts on cabinet rear wall.

Includes: battery charger/PSU
22V regulator for detector circuits
Brigade & Ancillary relays and supervision circuitry
MCP & door switch inputs
screw terminals (most demountable) for field wiring
FRC connection to other modules.

8 Zone Module

Mounts on cabinet rear or in Cardframe.

Includes: electronics to I/F to 8 Alarm Zone Circuits (AZCs)
8 open collector auxiliary outputs
demountable screw terminals for field wiring
FRC connection to other modules.

8 Relay Module

Mounts on cabinet rear or in Cardframe.

Includes: 8 relays and supervision circuitry
demountable screw terminals for field wiring
FRC connection to other modules.

16 Zone LED Display

Mounts on 7U inner door.

Includes: 16 sets of 3 LEDs; electronics to control the LEDs (serial bus).

RS485 Communications Bd

Mounts on RHS of cabinet.

Includes: Connecting FRC and mounting parts.

I-Hub Communications Bd

Mounts on RHS of cabinet.

Includes: Connecting FRC and mounting parts.

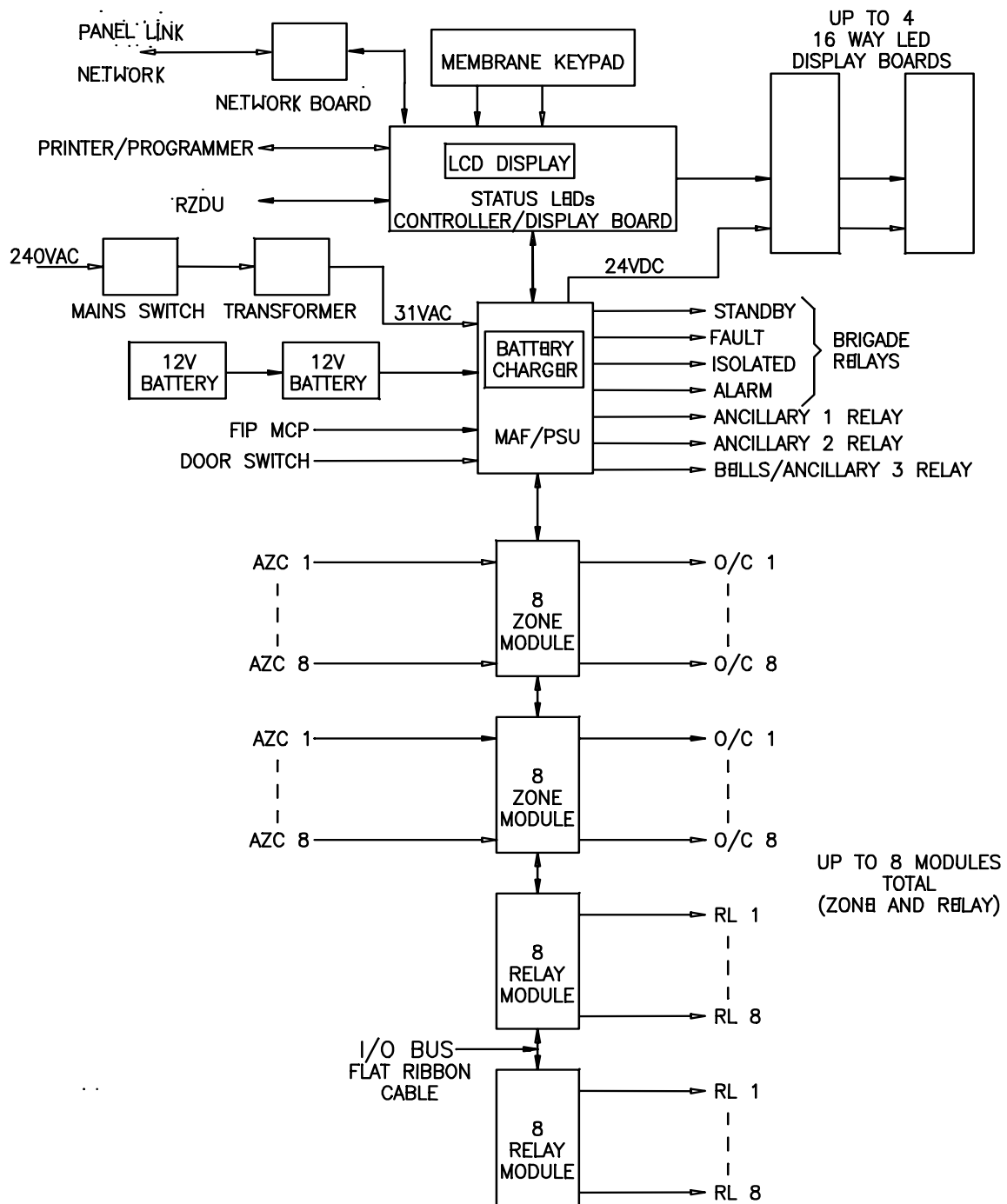

FIG 2.3.1
SYSTEM STRUCTURE

2.3.2 INTER-CONNECTION & STRUCTURE

A basic F3200 system has one Controller/Display, one MAF/PSU, and one 8 Zone Module, all connected by Flat Ribbon Cable (FRC) on a common Input/Output (I/O) Bus.

Additional 8 Zone Modules and/or 8 Relay Modules can be fitted to the I/O bus, with a maximum of eight 8 way modules. This is shown in the block diagram of Fig 2.3.1.

The physical maximums are:

- three 8 way modules in an FP0780 or FP0782.
- four 8 way modules in an FP0784 (with restrictions)
- eight 8 way modules in an FP0781 or FP0783.

Expansion is from top to bottom.

The I/O Bus Out of one module connects to the I/O Bus In of the next module via the 20 way FRC provided (LM0053). No link or "End of Bus" is required on the last module.

To further extend these capabilities, up to 64 F3200s may be networked together, with full sharing of information and remote control of each panel by a master panel.

16 Zone LED Display Bds are driven from a separate serial bus on the Controller/Display. They receive power from the MAF/PSU via two power leads. Where more than one is required they are connected in series (up to 4 maximum) from right to left (as viewed from the front) on the FIP. The 26 way FRC from J13 of the Controller goes to J1 ("From Previous") of the right hand Display Bd. Zone 1 (default) corresponds to the top LEDs on the left hand Display Bd. The last board requires the "end of bus" Minijump connector to be fitted. Note that a special FRC cable is required to connect the Controller Board to the first Display Board (LM0092).

Where LED Display Bds are fitted, the default programming requires one Display Bd (16 zones) for every two 8 Zone or 8 Relay Modules, i.e. one for 1-16 zones, two for 17-32 zones, etc.

Zone 1 corresponds to the top row of 3 LEDs on the left most Display. Zone 2 to the row below it, etc, (top to bottom, left to right).

LED Display Bds may also annunciate relay status, i.e. Alarm = relay energised, Isolated = relay isolated, Fault = relay wiring fault (i.e. supervision fault). The relay LEDs simply follow the zone LEDs in the same order that they occur in the modules. E.g. a system with three 8 Zone Modules and two 8 Relay Modules would require 3 Display Bds. Relay 1 would be annunciated on the 25th row of LEDs and the last 8 rows would be unused.

Mapping zones and relays to LEDs in other patterns is programmable.

CHAPTER 3

SYSTEM SPECIFICATIONS

3.1 GENERAL

3.1.1 FIP PART NUMBERS & DESCRIPTION

(Refer also to 3.8 following).

FP0780, F3200 AS4428 FIP, NO CARDFRAME, 24 ZONE MAX, 1931-95

FP0782, F3200 AS4428 FIP, NO CARDFRAME, 24 ZONE MAX, 1931-95, 6A PSU

Includes: Full size cabinet
Controller/Display with Operator Display & Keypad
MAF/PSU (includes 7 relays, 3A/6A Battery Charger)
1 x 8 Zone Module with standard EOLRs
Modules fit to cabinet rear wall (up to 3 modules max)

FP0781, F3200 AS4428 FIP, C/W CARDFRAME, 64 ZONE MAX, 1931-95

FP0783, F3200 AS4428 FIP, C/W CARDFRAME, 64 ZONE MAX, 1931-95, 6A PSU

Includes: Full size cabinet
Controller/Display with Operator Display & Keypad
MAF/PSU (includes 7 relays, 3A/6A Battery Charger)
Cardframe (can house up to 8 modules)
1 x 8 Zone Module fitted in Cardframe
includes standard EOLRs

FP0784, F3200 AS4428 FIP, SMALL CABINET, 1931-71, 8 ZONE

Includes: Small size cabinet
Controller/Display with Operator Display & Keypad
MAF/PSU (includes 7 relays, 3A Battery Charger)
1 x 8 Zone Module with standard EOLRs
Modules fit to cabinet rear wall (up to 4 modules max)

FP0876, F3200 AS4428, 8U CAB, 3A, 1U GAS CTL, PRE-PROG

Includes: FP0784 with 1 x 8 Relay Module and ME0442 fitted, wired and programmed as a gas release panel.

FP0877, F3200 AS4428, STD CAB, 6A, 1U GAS CTL, PRE-PROG

Includes: FP0782 with 1 x 8 Relay Module and ME0442 fitted, wired and programmed as a gas release panel.

3.1.2 SYSTEM EXPANSION

Expansion to the base panels is by adding 8 way Zone or Relay Modules, or by networking multiple panels together.

FP0553, F3200 8 ZONE INPUT EXPANSION KIT

Includes: 8 Zone Module, FRC, 8 x EOLR (std).

FP0554, F3200 8 RELAY EXPANSION KIT

Includes: 8 Relay Module, FRC, 8 x Minijump links (for supervision selection).

3.1.3 ENVIRONMENTAL

Operating Temperature : -5°C to 45°C (Ambient)
Relative Humidity : 95% maximum @ 40°C (non-condensing)

3.2 MECHANICAL SPECIFICATIONS

CABINETS

Style	: Wall mounting Hinged outer door with large window (hinges to left) Accepts 19" rack mounting equipment 4U Display on hinged inner door (hinges to right)																								
Construction	: Welded steel																								
Material	: 1.2mm and 1.6mm mild steel																								
Size	:																								
- Standard	: 750mm (H) x 550mm (W) x 210mm (D) * (Iss B cabinet)																								
- Small	: 410mm (H) x 550mm (W) x 210mm (D) *																								
	* MCP is an additional 20mm.																								
Finish	: Powdercoat BFF-998-CW Cream Wrinkle (Iron Phosphate pre-treat)																								
Weight	<table style="border-collapse: collapse; width: 100%;"> <thead> <tr> <th style="width: 10%;"></th> <th style="text-align: center; width: 40%;">Unpackaged</th> <th style="text-align: center; width: 50%;">Packaged</th> </tr> </thead> <tbody> <tr> <td>FP0780</td> <td style="text-align: center;">21kg</td> <td style="text-align: center;">24kg</td> </tr> <tr> <td>FP0781</td> <td style="text-align: center;">25kg</td> <td style="text-align: center;">28kg</td> </tr> <tr> <td>FP0782</td> <td style="text-align: center;">23kg</td> <td style="text-align: center;">26kg</td> </tr> <tr> <td>FP0783</td> <td style="text-align: center;">25kg</td> <td style="text-align: center;">29kg</td> </tr> <tr> <td>FP0784</td> <td style="text-align: center;">17kg</td> <td style="text-align: center;">19kg</td> </tr> <tr> <td>FP0876</td> <td style="text-align: center;">19kg</td> <td style="text-align: center;">21kg</td> </tr> <tr> <td>FP0877</td> <td style="text-align: center;">25kg</td> <td style="text-align: center;">28kg</td> </tr> </tbody> </table>		Unpackaged	Packaged	FP0780	21kg	24kg	FP0781	25kg	28kg	FP0782	23kg	26kg	FP0783	25kg	29kg	FP0784	17kg	19kg	FP0876	19kg	21kg	FP0877	25kg	28kg
	Unpackaged	Packaged																							
FP0780	21kg	24kg																							
FP0781	25kg	28kg																							
FP0782	23kg	26kg																							
FP0783	25kg	29kg																							
FP0784	17kg	19kg																							
FP0876	19kg	21kg																							
FP0877	25kg	28kg																							

3.3 ELECTRICAL SPECIFICATIONS

3.3.1 MAINS SUPPLY

Voltage	:	240Vac +6% -10%
Current	:	0.5A
Frequency	:	50Hz
Termination	:	For up to 2.5sq mm TPS 3 Way block with wire protectors

3.3.2 BATTERY CHARGER & PSU

Input Voltage (Transformer sec)	:	31Vac rms
Charger Voltage	:	27.3Vdc (nominal at 20°C)
Temperature Compensation	:	-36mV per °C nominal
Non-Battery Backed Voltage	:	28.0 nominal
Max Total Current	:	3Adc for std PSU (Charger, Quiescent & Alarm) 6Adc (for 6A PSU only)
Max Warning System Current	:	2Adc
Max. Ancillary Current on VBF1	:	2Adc
Max. Ancillary Current on VBF2	:	2Adc (allows 3A max LED Display)
Max. Ancillary Current on VNBF	:	2Adc (e.g. for door holders)

(VBF <-> battery backed, fused. VNBF <-> non-battery backed, fused)

Current Limit	Standard PSU	6A PSU
Battery to MAF/PSU	:	PTC, 6A nom, 3.6A min (see notes below)
PSU/Charger	:	3.3A nom, 3.0A min 6.7A nom, 6.0A min

- Notes
- 1) : The 6A PSU is factory fitted in the FP0782 and FP0783. It is not available in the FP0784.
 - 2) : For the 6A PSU, the PTCs on the MAF are shorted out and a Derwent 10A thermal cut-out is wired between the battery + terminal and the MAF/PSU.

BATTERY CHARGER & PSU (CONTINUED)

STATE	MIN	NOM	MAX	COMMENTS
Charger High	28.05	28.125	28.20	Adjust with pot
Charger Low	26.40	26.57	26.75	
Battery Low	24.15	24.33	24.55	
Standby Off	21.5	22.0	22.5	For voltage falling

Notes:

1. All voltages stated in VDC at temperature of 20°C.
2. Apply temperature compensation of -36 mV/°C for temperature deviation from 20°C.
3. This applies also to charger voltage 27.3 VDC.
4. There are thermal delays, therefore if checking or adjusting in field ensure unit has been running for some hours.
5. Standby Relay is normally energised (on), and turns off for Battery fail.

TABLE 3.3.2
BATTERY AND CHARGER MONITORING VOLTAGE SPECIFICATIONS

3.3.3 BATTERY

Battery Voltage	:	24Vdc nominal (2 x 12Vdc)
Compatible Makes	:	Century Yuasa PS series IRH BB Battery BP series Panasonic LC-L, LC-R and LC-X series YHI Power CSB GP series Yuasa NP series
Capacity	:	6 to 50 Ahr (dependent on configuration)
Space (mm)	:	- Standard Cabinet Up to 220H, 440W, 175D (Iss B cabinet) - Small Cabinet Up to 200H, 185W, 175D (3 modules fitted) Up to 200H, 370W, 125D (4 modules fitted) (Refer to Fig 2.2.2)

3.3.4 FUSES

Location	:	MAF/PSU PCB
----------	---	-------------

<u>Number</u>	<u>Name</u>	<u>Size</u>	<u>Rating</u>	<u>Type</u>
F1	+VBF1	5 x 20mm	2A	Glass Cartridge, Std
F2	+VBF2	5 x 20mm	6A	Glass Cartridge, Std
F3	+VNBF	5 x 20mm	2A	Glass Cartridge, Std
F4	+VE	5 x 20mm	2A	Glass Cartridge, Std
F5	Mains In	5 x 20mm	6A	Glass Cartridge, Std
F7	+VBELLS	5 x 20mm	2A	Glass Cartridge, Std

3.3.5 CURRENT CONSUMPTION

3.3.5.1 F3200 Quiescent & Alarm Currents

At 24Vdc battery supply, nominal currents:

	<u>Quiescent</u>	<u>Alarm (2 Zone)</u>
Base Panel (notes 1-4)	130mA	275mA
8 Zone Module		
- all AZCs disabled	4mA	
- all AZCs enabled (notes 2-6)	82mA	97mA
Current per enabled AZC (note 3)	10mA	
8 Relay Module		
- all supervision disabled	4mA	
- all supervision enabled	6mA	
Current per relay on	11mA	
MAF/PSU		
- all relays off	9mA	
Current per Ancillary Relay (includes bells)	11mA	11mA
Current per Brigade Relay	16mA	16mA
22V Supply (supplies 8 Zones) max rating		800mA
Controller/Display		
- LCD backlight off, status LEDs off	19mA	
- LCD backlight on, status LEDs off	75mA	
Current per status LED on	3mA	
16 Zone LED Display	0mA	16mA/LED (steady)
RS485 network interface board PA0773	7.5mA	
Total electronics and detector max rating	2000mA	

Notes

1. The base panel includes Controller/Display, MAF/PSU and 1 x 8ZM with all ACZs enabled and with EOLRs (2K7 for mode 1 or 2).
2. Quiescent current for an enabled AZC is for modes 1 or 2 (standard or high current) and includes the 2k7 EOL, but not the detector current (up to 4mA detector current per AZC).
3. Quiescent current is only 2.5mA per AZC for mode 3 and 1mA for mode 4.
4. Alarm current is for AZC mode 1, refer AZC specifications for other modes.
5. The 8 Zone Modules (8ZMs) are supplied from the fused battery supply via the 22V regulator which has a maximum rating. The 8 Relay Modules (8RMs) are supplied directly from the fused battery supply.
6. Quiescent and alarm currents do not include external loads e.g. door holders, bell, sounders etc.

3.3.5.2 NDU Quiescent and Alarm Currents

Slimline NDU (FP0791/FP0792/FP0793/FP0794)

Operating Voltage : 24Vdc (18-28V)
Termination : For up to 2.5sqmm TPS

Current Consumption :	<u>Quiescent</u>	<u>Alarm</u>
	25mA	80mA

Full cabinet NDU (FP0790)

Current Consumption (Aust mode) ¹	<u>Quiescent</u>	<u>Alarm</u>
	70mA	165mA
Current Consumption (NZ mode) ²	85mA	150mA

1. Includes controller, MAF/PSU, energised standby relay, PA0773 RS485 Bd, LCD backlight off in quiescent state.
2. Includes controller, MAF/PSU, NZ Display Extender, energised standby and alarm relays, PA0773 RS485 Bd. LCD backlight off in quiescent state.
3. Refer to Section 3.3.5.1 for additional module currents.
4. For FP0793 the I-Hub current needs to be added.

3.4 INPUT SPECIFICATIONS

3.4.1 AZC SPECIFICATIONS

General

Terminations	On 8 Zone Module, 2 per AZC. Demountable screw terminal 1.5sq mm cable max.
Number	8 AZCs per 8 Zone Module. 64 max per panel.

End of Lines (EOLs)

Mode	EOL
1 Standard	2k7, 5%, 400mW resistor
2 High Current	2k7, 5%, 400mW resistor
3 Low Current	10k, 5%, 400mW resistor
4 Tamper	EOL002B active EOL
5 Disabled	None

Circuit Resistance & Capacitance

Mode	Capacitance	Resistance
1, 2 & 4	500nF	50 Ohm max
3	1000nF	800 Ohm max for B2 Alarm 2k Ohm max for B3 Alarm

Voltages

		Min	Typ	Max
Detector Supply	on MAF/PSU (note 1)	21.2V	22.0V	22.2V
	at AZC terminals	(21.8V)		
	at end of circuit	18.75V	20.3V	22.1V
		18.0V	20.3V	22.1V

Alarm Voltage Thresholds

Band B3 upper threshold	17.2V	17.5V	17.8V
Band B3 lower threshold	12.75V	13.1V	13.45V
Band B2 upper threshold			
Band B2 lower threshold	2.7V	2.9V	3.1V
Band B1 upper threshold			
Band B1 lower threshold	0V	0V	0V

AZC SPECIFICATIONS (CONTINUED)

	Min	Typ	Max
AZC current limit (note 1)	13.5mA (14.5mA)	15.5mA	16.5mA
EOL & detector quiescent			11.95mA
EOL, no detectors	7.0mA (7.2mA)	7.8mA	8.2mA
Fault threshold	4.4mA	5.75mA	6.8mA
Detector quiescent	0mA		4.0mA

Notes

1. The minimum figures shown are for battery voltage greater than the minimum Standby (Battery Fail) level i.e. 21.5V. The figures shown in brackets are for a battery voltage greater than 22.5V.
2. Modes 1 & 2 have the same thresholds before the Alarm state is latched. For Mode 2 additional current is turned on once the Alarm state is latched (refer to Graph 3.4.2).

	Min	Typ	Max
Mode 3 Only			
Current into short circuit			34.3mA
Current into 800 Ohm (note 3)	14.2mA	14.8mA	15.3mA
Current into 2000 Ohm (note 4)	8.0mA	8.2mA	8.4mA
EOLR Current		2mA	
Minimum current for EOLR & 2k circuit	1.64mA		

Modes 3 & 4

Fault thresholds	0.85mA	1.28mA	1.59mA
Maximum allowable load or circuit leakage			0.5mA

Notes

3. I.e. short at end of an 800 Ohm circuit (gives voltage band B2 alarm, ref. graph 3.4.1).
4. I.e. short at end of a 2000 ohm circuit (gives voltage band B3 alarm, ref. graph 3.4.1).

MCP Zener Diode

For voltage band B3 operation BZT03C15 3W, 15V.

Detector Alarm Currents

The current available to a latched detector is the AZC supply current at the detector "Alarm" voltage minus the EOLR current and the remaining quiescent current at that voltage.

The following graphs show current/voltage characteristics for the various modes of operation.

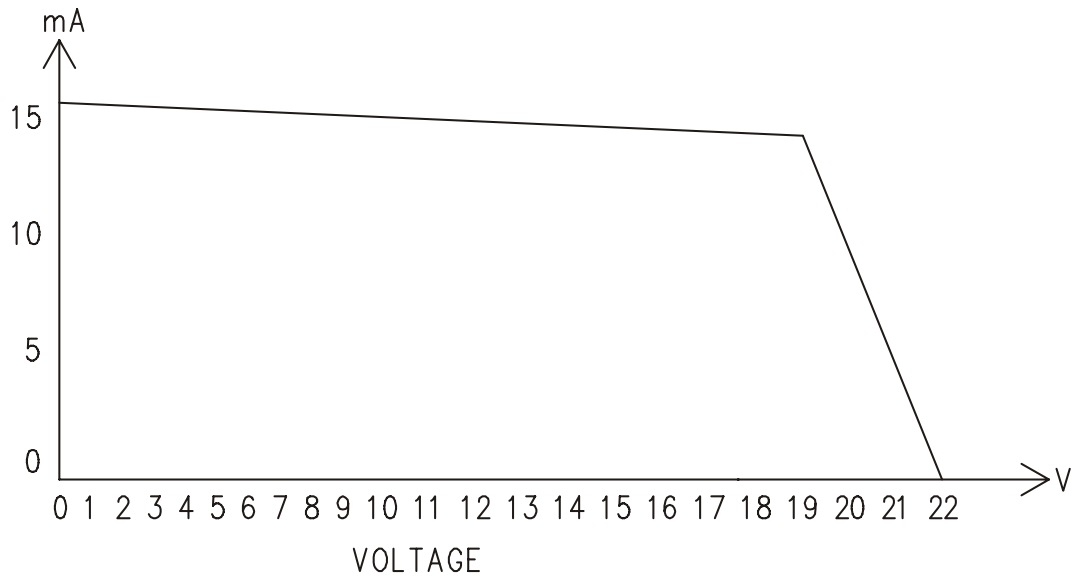

GRAPH 3.4.1
AZC CURRENT LIMIT CHARACTERISTICS (MODES 1 & 2)

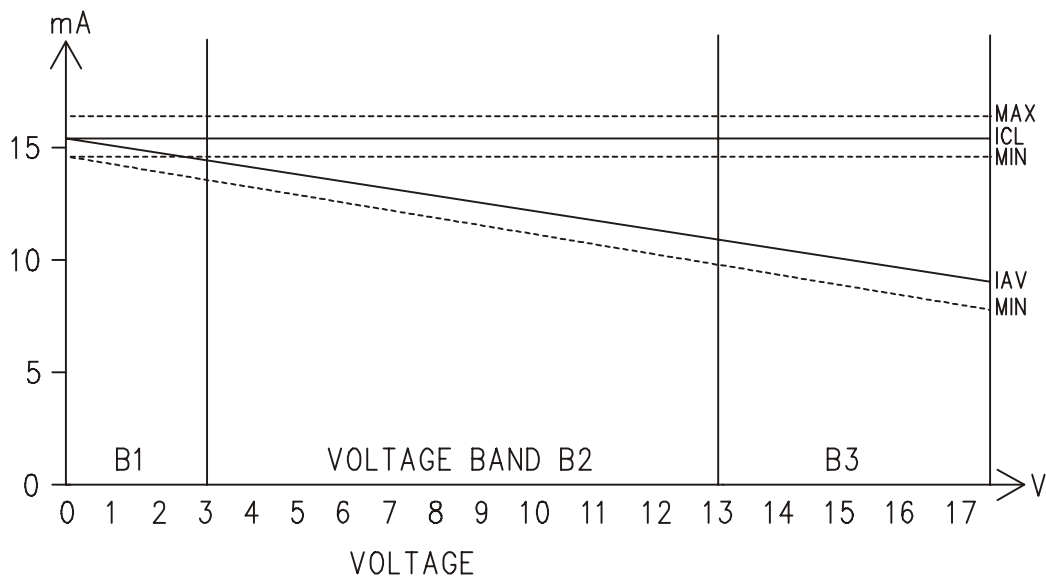

ICL = Current Limit
IAV = Current Available to Detectors with EOLR fitted
IAV = ICL - IEOLR

GRAPH 3.4.2
AZC CURRENT VS VOLTAGE : MODE 1 (STANDARD)

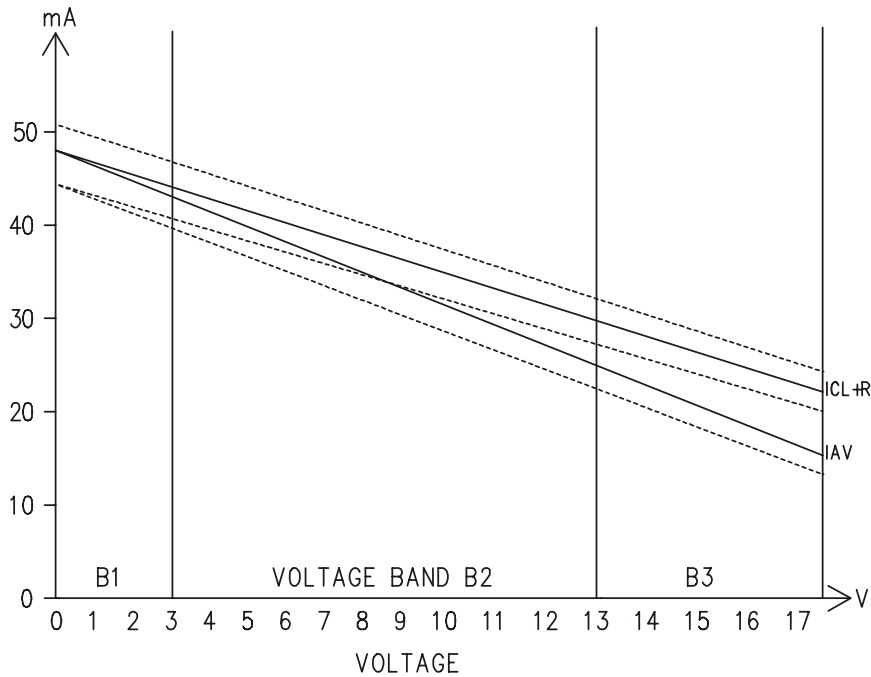

ICL+R = Current sourced through current limit and pull up resistor
 IAV = Current available to detectors with EOLR fitted
 $IAV = ICL+R - IEOLR$

GRAPH 3.4.3
AZC CURRENT VS VOLTAGE MODE 2 (HIGH CURRENT)

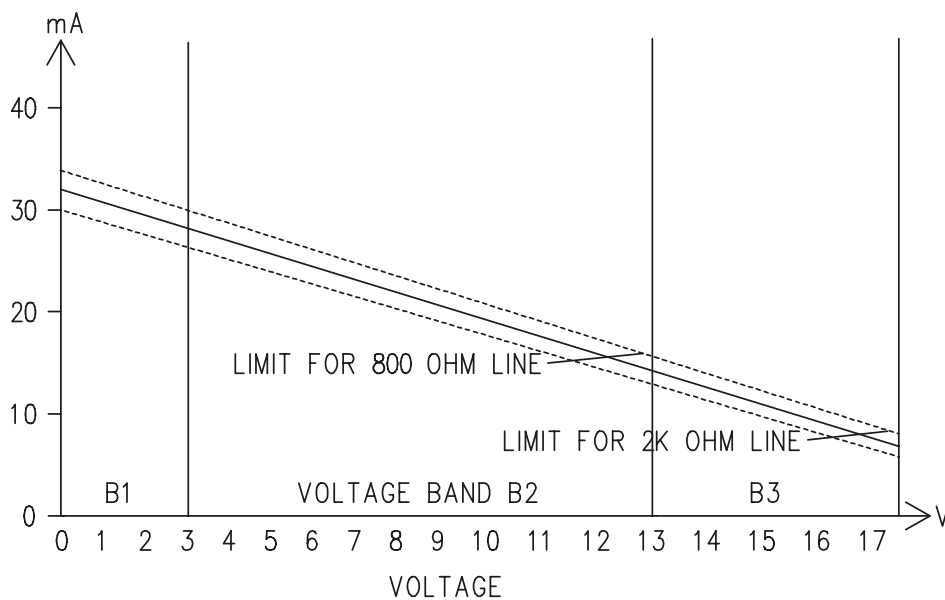

A short circuit at the end of an 800 Ohm line will give a B2 (Detector Operated) alarm.

A short circuit at the end of a 2k Ohm line will give a B3 (programmable) condition.

GRAPH 3.4.4
ACZ CURRENT VS VOLTAGE MODES 3 & 4 (LOW CURRENT & TAMPER)

AZC SPECIFICATIONS (CONTINUED)

Timing

Standard Delay (into Alarm, Fault, Normal)	2.3 sec (2.0 - 2.6 sec)
AZC Reset	5.3 sec (5.0 - 5.6 sec)
AZC Ignore Period 1 (after Reset)	2 sec nom (plus std 2.3 sec delay)
AZC Ignore Period 2 (after Start Up or Programming)	1 sec nom (plus std 2.3 sec delay)
AZC Time Into Alarm	Programmable 0-250 sec
AZC Time Out of Alarm	Programmable 0-250 sec

3.4.2 MAF/PSU INPUTS

Battery Termination	One pair screw terminals; 4sq mm max cable
AC Input	31V rms; 3.6A rms; 2.8mm tab terminals
Door Switch	5V, 0.5mA, Unsupervised, 4 Way .1" pcb header, J6
MCP	5V, 1mA, 2k7 EOLR, 4 Way .1" pcb header, J6
Spare Inputs (not fitted)	5V, 0.5mA, Unsupervised, Cabinet internal use only, 4 Way .1" pcb header, J5

Relay Supervision

Anc 1 Sup/Anc 2 Sup	One screw terminal each
Modes of Operation	1 Door holder 2 Load

	<u>Relay Off</u>	<u>Relay On</u>
1. Door Holder Mode expects	Voltage Present	No Voltage Present
2. Load mode expects	Resistive to 0V	Open Circuit or Voltage Present
Default Modes Anc 1 Anc 2	Door Holder, Disabled Load, Disabled	
Voltage Threshold (Door Holder Mode)	3.65V Nom	
Supervision Current	0mA @ +5V, 1mA @ 0V	

MAF/PSU INPUTS (CONTINUED)

Load Resistance (Load Mode)	400 Ohm - 10k Ohm less than 400 Ohm with series diode at load. 14 Ohm absolute minimum.	
Anc 3 Supervision		
Input Termination	Output terminals BELLS +, -	
Form	Reverse polarity - requires series diode at each device Resistor EOL	
End of Line	No. of <u>Circuits</u>	<u>Type</u>
	1	3k3, 5%, 250mW resistor
	2	6k8, 5%, 250mW resistor
	3	10k, 5%, 250mW resistor
Supervision Current	0mA @ +5V, 1.5mA @ 0V, +ve to BELLS- terminal	
Circuit Resistance	100 Ohm max.	

3.4.3 CONTROLLER/DISPLAY INPUTS

Spare DC Input/Output	24Vdc nom Demountable screw terminal, 4 way, J5	
Spare Input	22V, 10k Ohm pull up resistor Provision for supervision (up to 5 band)	
Spare Inputs IP0, 1, 2 (not fitted)	Unsupervised Cabinet internal use only +5V, 100k pull up resistor 10 Way FRC header, J10	
Serial I/O	RZDU Refer Section 3.5.3; Others 3.5.2	

3.4.4 8 RELAY MODULE SUPERVISION

Form	Load monitoring	
Expects	<u>Relay Off</u> Resistance to 0V	<u>Relay On</u> Voltage Present
Selected By	Minijump link on PCB & programming of FIP	
Default Programming	Supervised	
Load Resistance	400 Ohm - 10k Ohm Less than 400 Ohm with series diode at load 14 Ohm absolute minimum	
Voltage Threshold	3.65V nom.	
Supervision Current	0mA @ +5V, 1mA @ 0V	

3.4.5 NZ MODE DISPLAY EXTENDER BOARD INPUTS

The Display Extender Board is used with New Zealand operation only. The inputs it provides are: Silence Alarms, Trial Evac, Building Services Restore, Lamp Test and External Defect. All inputs have closure to zero volts to assert the input. An input may be left open or unconnected if not used. Refer to section 5.11 for wiring.

All Inputs	Closure below 1.5V @ 0.35mA required to activate. Open voltage = 5V
------------	--

3.5 OUTPUT SPECIFICATIONS

3.5.1 8 ZONE MODULE OUTPUTS

Type	Darlington open collector, switch to 0V
Voltage Rating	28.5V max, "off" state 1.1V max at 100mA "on" state
Current Rating	100mA max per O/P, 0.6A max per module, 1A max per FIP.
Transient Protection	Allows external wiring
Terminations	8 Way demountable screw terminal, 1.5sq mm max. cable
Operation	Programmable
Default	O/C 1 = Zone 1 Alarm O/C 2 = Zone 2 Alarm, etc.

3.5.2 8 RELAY MODULE OUTPUTS

Form	1 Pole changeover contacts Voltage-free when unsupervised
Termination	Demountable screw terminals, 1.5sq mm max cable
Rating	30V, 1Adc inductive , 30V, 2Adc resistive
<u>Note</u>	The relays are 2 pole, with the second pole terminated on PCB pads.
Operation	Programmable
Supervision	Ref. 3.4.4.
Looping Terminals	2 Sets of 4 joined voltage-free terminals per module

3.5.3 MAF/PSU OUTPUTS

Brigade Relays

Standby	Normally energised, De-energises on battery fail or panel fail
Fault, Isolated, Alarm	Normally de-energised, Energise on active state
Form	1 Pole voltage-free changeover contacts
Termination	Demountable screw terminals 1.5sq mm max cable
Rating	30V, 3Adc inductive, 30V, 5Adc resistive
Isolation	1500V rms contact to coil

MAF/PSU OUTPUTS (CONTINUED)

Ancillary & Bells

Anc 1, Anc 2	1 Pole voltage-free changeover contacts
Termination	Demountable screw terminals, 1.5sq mm max cable
Rating	30V, 1Adc inductive, 30V, 2Adc resistive

(Note: The relays are 2 pole, with second pole terminated on PCB pads).

Operation Default	Programmable (refer Programming Manual) (Anc 2 is External Bell)
Supervision	Separate terminal (ref 3.4.2)

Anc 3/Bells	2 pole relay Link selectable function
--------------------	--

Standard Format	Polarity reversal, switched 24Vdc output 2 terminals, Bells +, - Demountable screw terminals, 1.5sq mm max cable
-----------------	--

Option	1 Pole voltage-free changeover contacts Snip Links Lk2, 3, 4.
--------	--

Rating	30V, 2Adc resistive, 30V, 1Adc inductive
--------	--

Operation Default	Programmable (refer Programming Manual) Warning System
----------------------	---

Supervision	On Bells +, - terminals only (ref Section 3.4.2)
-------------	--

Power Supply Outputs

0Vdc

Termination	1 non-demountable screw terminal, 4sq mm max cable 2 demountable screw terminals, 1.5sq mm max cable 1 2.8mm tab terminal (LED Display)
-------------	---

Battery Backed DC Supply

Rating	27.3Vdc (24V battery nom), 2Adc, fused.
+VBF1	1 non-demountable screw terminal, 4sq mm max cable 1 demountable screw terminal, 1.5sq mm max cable
+VBF2	1 non-demountable screw terminal, 4sq mm max cable 1 demountable screw terminal, 1.5sq mm max cable 1 2.8mm tab terminal (LED Display)

Non-Battery Backed DC Supply

Rating	28Vdc nom, 2Adc, fused
--------	------------------------

MAF/PSU OUTPUTS (CONTINUED)

+VNBF 1 non-demountable screw terminal, 4sq mm max cable
1 demountable screw terminal, 1.5sq mm max cable

RZDU Comms

Tx, Rx, 0V 3 Wire (+VBF2 available for 4th wire)
Transmission Rate 1200 Baud
Protocol Vigilant F4000
Termination Demountable screw terminals, 1.5sq mm max cable

3.5.4 CONTROLLER/DISPLAY OUTPUTS

Spare Parallel Outputs (not fitted)

Number, Rating 6, CMOS 0-5V
Termination 10 Way FRC PCB header, J10

Serial I/O

Printer/Programmer Port (This is same port as Serial Port 0)

Form Pseudo RS232, Rx, Tx, 0V signals only
Transient Protection Allows external wiring
Transmission Rate 9600 Baud
Protocol ASCII Xon, Xoff
Termination 4 Way .156" male Molex (J1),
9 Way Miniature D available via
LM0041.
Female Pins (socket)

Pin 2 3 5 1 4 6 7 8
Tx Rx 0V

25 Way Miniature D available via LM0042
Female Pins (socket)

Pin 2 3 7 6 8 20
Rx Tx 0V

Also available as 9 way male D connector (J27)

Serial Port 0 10 Way FRC header, J2
UART signals: RXD, TXD, RTS-, CTS-, DCD-
5V levels; 0V, +5V, +24V also available

Network 1 10 Way FRC header, J7
Network 2 10 Way FRC header, J9
UART signals for Network 1/2
RXD, TXD, RTS-, CTS-, DCD-
5V levels; 0V, +5V, +24V also available

3.5.5 NZ DISPLAY EXTENDER BOARD OUTPUTS

This is used in New Zealand mode only. Refer to section 5.11 for wiring of the outputs on the unprotected termination board. The Display Extender Board already has common Normal, Defect and Fire status LEDs fitted to it, but these may be replicated externally if necessary. There are also ancillary defect and fire outputs which are active low open collector, and an output to drive an index lamp.

All Outputs (except LAMP)	Open collector pulldown to 0V Off voltage = 30Vmax On voltage = 1.1V @ 100mA (max) On Current = 100mA max
LAMP +	Open collector pull up to VBATT Off voltage = 0V On voltage = VBATT-1V On current = 400mA max
LAMP -	Connected to Battery –

3.6 CONTROLS

KEYPAD

Type	:	Polyester Membrane
Keypress	:	Buzzer gives short "beep" for valid keypress
FF Keys	:	EXTERNAL BELL ISOLATE; WARNING SYSTEM ISOLATE; PREV; NEXT; ACK; RESET; ISOLATE
4x4 Keypad	:	Digits 0-9; Clear/Esc; Enter; 4 x Logic Keys
Zone Functions	-	Alarm, Fault and In-Situ Test; Isolate, Reset, Recall
Ancillary Functions	-	Test, Isolate, Reset, Recall
Relay Functions	-	Test, Isolate, Reset, Recall
System Functions	-	Battery Test, Buzzer Test, Display Test, System Test Bell Test, External Bell Isolate, Warning System Isolate Recall : Alarms, Faults, Isolates, System Faults, History Set time and date Program and view parameters Print and save database
Brigade Functions	-	Acknowledge Alarms View alarms (Next & Prev) Reset acknowledged zone in alarm Isolate acknowledged zone in alarm Brigade Test (via menu)

BUZZER (INTERNAL SOUNDER)

Tone Steady	:	Fault, System Fault Unisolated zone (note 1) or relay supervision fault (note 2) Sounder re-sounds 8 hours after silence.
Pulsing 2Hz	:	Unisolated zone alarm (note 1)
Slow Pulse	:	Door closed with Database Write Enabled (Lk7) or in Program Mode.
Cadence	:	Zone or In-Situ Test failed (note 3)
Short Pulse	:	Valid keypress
Long Pulse	:	Invalid keypress

Notes:

- 1) For zones not mapped to MAF (status only) the buzzer does not turn on (dependent also on programming of FF).
- 2) For relay supervision not mapped to MAF the buzzer does not turn on.
- 3) Cadence is repeated fast pulses with a pause.

NDU NZ MODE KEYSWITCHES

Brigade Functions	-	Trial Evacuation, Silence Alarms, Services Restore
-------------------	---	--

3.7 DISPLAYS

Standard Display

Includes	:	LCD; FF LEDs; System Status LEDs
Panel Size	:	19", 4U
LCD Size	:	2 Lines of 40 characters, 5.5mm (H) x 3.2mm (W) per character
Site Name	:	40 Characters max.
Zone Name	:	30 Characters max.
Relay Name	:	30 Characters max.
FF LEDs	:	ALARM (red); ISOLATED (yellow); FAULT (yellow); EXTERNAL BELL ISOLATE (yellow); WARNING SYSTEM ISOLATE (yellow)
System		
Status LEDs	:	MAINS ON (green); CHGR/BATT FAULT (yellow); SYSTEM FAULT (yellow); AIF ATTENDED (yellow)
Internal	:	Mains On (green), Fuse Blown (yellow) on MAF/PSU PCB.
Status LEDs		

Optional Additional LED Display

Requires 1 x ME0060 plus 1 x FZ3031 plus 1-3 x FP0475 as required.

ME0060, MECH ASSY, 1901-79, F4000 RAC, EXT INNER DOOR
(19", 7U, mounts up to 4 of 16 LED Display Bd)

FZ3031 KIT, F3200, 16 ZONE LED DISPLAY, LHS POSITION

FP0475, FP, F4000 DISPLAY EXTENDER KIT, 1901-26

Includes	:	1 x 16 LED Display Bd (16 zone parallel LED display); FRC; Power leads; zone name label.
Format	:	7U Parallel LED display mounts directly below the standard 4U LCD.
Zone LEDs	:	ALARM (red); FAULT (yellow); ISOLATED (yellow)
Name Space	:	10mm x 60mm per zone on paper label. E.g. 2 lines of 23 characters at 10 per inch.

New Zealand Mode Display Extender Board (applicable to NDU only)

Status LEDs: NORMAL (green), DEFECT (yellow), FIRE (Red)

PA0499,PCB ASSY,1901-119-1,F4000 NZ DISPLAY EXTENDER

3.8 ORDERING INFORMATION

The following lists the part numbers for the range of products and spares associated with an AS4428 F3200. It includes a brief description where considered necessary.

FA1227,FAB,1931-24,F3200 BLANK PANEL,PLASTIC,9.5U

FA1235,FAB,1919-27-5,F3200,FLUSH SURROUND (P) (STD CABINET)

FA1298,FAB,1919-27-6,F3200,SMALL FLUSH SURROUND (P)

FA1299,FAB,1919-27-7,F3200,STD + BATT BOX,FLUSH SURROUND (P)

FP0475,16 ZONE LED DISPLAY EXTENDER KIT,1901-26

(includes Display Bd, 0.5m FRC, power leads and label master. Cannot be used for first LED Display. See FZ3031)

FP0553,F3200 8 ZONE INPUT EXPANSION KIT

(ref Section 3.1.2)

FP0554,F3200 8 RELAY EXPANSION KIT

(ref Section 3.1.2)

FP0556,F3200 CABINET,EMPTY,C/W DOOR,WINDOW,LOCK

FP0557,F3200 CABINET,EMPTY,C/W BLANK OUTER DOOR

FP0570,FP,1937-3-1,LOCAL GAS CONTROL STATION,AUTO

(wall mounting box with flip cover break glass "Gas Start" switch and double action toggle "Gas Inhibit" switch, includes buzzer and LEDs)

FP0572,FP,1937-3-2,LOCAL GAS CONTROL STATION,MANUAL

(as per above, but without "Gas Inhibit" switch, LED and buzzer)

FP0576,FP,F3200,BATTERY BOX

FP0584,FP,F3200,SMALL EMPTY CABINET,FULL WINDOW

FP0780,FP,F3200 AS4428 FIP,NO CARDFRAME, 24 ZONE MAX,3A

FP0781,FP,F3200 AS4428 FIP,C/W CARDFRAME,64 ZONE MAX,3A

FP0782,FP,F3200 AS4428 FIP,NO CARDFRAME,24 ZONE MAX,6A

FP0783,FP,F3200 AS4428 FIP,C/W CARDFRAME,64 ZONE MAX,6A

FP0784,FP,F3200 AS4428 FIP,SMALL CABINET,MAF/PSU,3A, 8 ZONE

FP0790,FP,NDU AS4428,NETWORK DISPLAY,FULL CAB,MAF/PSU,3A

FP0791,FP,NDU AS4428,NETWORK DISPLAY,SLIMLINE,SURFACE

FP0792,FP,NDU AS4428,NETWORK DISPLAY,SLIMLINE,FLUSH

FP0793,FP,NDU AS4428,NETWORK DISPLAY,DEEP SLIMLINE,C/W I-HUB

FP0794,FP,NDU AS4428,NETWORK DISPLAY,4U 19" MODULE

FP0795,FP,F3200 AS4428 NETWORK UPGRADE KIT,V3.XX

FP0876,FP,F3200 AS4428 FIP,8U CAB,3A,1U GAS CTL,PRE PROG

FP0877,FP,F3200 AS4428 FIP,15U CAB,6A,1U GAS CTL,PRE PROG

FZ3031,KIT,F3200,16 ZONE LED DISPLAY,LHS POSITION

(FP0475, but with 1.2m FRC, allows mtg of first Display Bd in furthest left position).

FZ9002,FP,19" RAC,7U BLANK INNER DOOR

ORDERING INFORMATION (CONTINUED)

KT0072,KIT,F3200,CARDFRAME UPGRADE

KT0111,KIT,1945-1-1,AS1668 CONTROL MODULE,TYPE 1

KT0112,KIT,1945-1-2,AS1668 CONTROL MODULE,TYPE 2

KT0113,KIT,1945-1-3,AS1668 CONTROL MODULE,TYPE 3

KT0199,KIT,ASE,3U 19" RACK MOUNTING FRONT PANEL

KT0212,KIT,V-MODEM,2 UP,3U 19" RACK MTG FRONT PANEL

KT0271,KIT,F3200,AS1603.4 V2.XX TO V3.XX STD UPGRADE

KT0272,KIT,F3200 AS1603.4 V2.XX NET TO V3.XX NET UPGRADE

KT0273,KIT,NDU AS1603.4 V2.XX TO V3.XX S/W UPGRADE

KT0274,KIT,F3200 FIP,AS1603.4 TO AS4428.1 CONVERSION

LM0041,LOOM,1888-58,PROG PORT TO 9 PIN SERIAL
(cable to connect printer/computer to Controller, has 9 pin min D)

LM0042,LOOM,1888-62,PROG PORT TO 25 PIN SERIAL
(cable to connect printer/computer to Controller, has 25 pin min D)

LM0044,LOOM,1901-81-1,DISPLAY EXTENDER FRC,2M

LM0045,LOOM,1901-81-2,DISPLAY EXTENDER FRC,5M

LM0046,LOOM,1901-81-3,DISPLAY EXTENDER FRC,0.5M

LM0049,LOOM,1901-81-4,DISPLAY EXTENDER FRC,0.25M

LM0053,LOOM,1931-28-1,F3200 20 WAY FRC,300MM
(standard FRC for interconnecting 8 way modules, included in FP0553, 554)

LM0092,LOOM 1901-88 CONTROLLER TO 1ST DISPLAY, FRC, 1.2M
(Display Bd to Controller, for Display Bd in furthest left position, included with FZ3031).

LT0121,LITERATURE,1931-19,F3200 TECHNICAL MANUAL

LT0250,LITERATURE,F3200 AS4428,OPERATOR'S MANUAL,A5

LT0254,LITERATURE,F3200 AS1603.4 TO AS4428 CONVERSION

LT0255,LITERATURE,F3200 AS4428,INSTALLATION AND CONFIG

LT0256,LITERATURE,F3200 AS4428,PROGRAMMING MANUAL

LT0263,LITERATURE,F3200 AS4428 REPLACEMENT CONTROLLER INSTALL

LT0264,LITERATURE,F3200 AS1603.4 V2.XX TO V3.XX UPGRADE

LT0266,LITERATURE,INSTALL V3.XX AS4428 S/W IN AS1603 F3200/NDU

ORDERING INFORMATION (CONTINUED)

ME0060,MECH ASSY,1901-79,RAC CABINET,EXT INNER DOOR
(hinged 7U inner door for mounting Display Bds on, includes screws, perspex window, cage nuts and PCB stand-offs)

ME0072,MECH ASSY,1931-70,F3200 RACK MTG GEARPLATE
(allows F3200 internals to be fitted to a RAC cabinet. Factory fit option only. See Note 1)

ME0098,MECH ASSY,1931-116,F3200 AS4428.1 CONTROL,4U HINGED

ME0250,MECH ASSY,1919-35,RAC CABINET,IP65,20U X 200 (i.e. waterproof)

ME0258,MECH ASSY,1919-21-2,RAC CABINET,1U SHELF,135 DEEP
(includes screws and cage nuts for mounting to FIP)

ME0438 MECH ASSY,1931-123,AS4428 1 ZONE GAS CNTRL 7U DOOR
ME0439 MECH ASSY,1931-123,AS4428 2 ZONE GAS CNTRL 7U DOOR
ME0440 MECH ASSY,1931-123,AS4428 3 ZONE GAS CNTRL 7U DOOR
ME0441 MECH ASSY,1931-123,AS4428 4 ZONE GAS CNTRL 7U DOOR
ME0442 MECH ASSY,1931-124,AS4428 1U 1 ZONE GAS CNTRL PNL
(ME0438-ME0441 are 7U screened doors with 1-4 zones of gas controls and indicators wired ready for connection to AS44428.1 F3200. ME0442 is a 1U bracket with 1 gas zone control/indication)

PA0443,PCB ASSY,1841-18,CONTACT CONVERSION MODULE

PA0703,PCB ASSY,1931-27,F3200 REMOTE I/F BD

PA0707,PCB ASSY,1931-39,F3200 3A RECTIFIER BD

PA0773,PCB ASSY,1901-139-3,RS485 COMMS BD,CMOS;FRC ONLY

PA0873,PCB ASSY,1931-3-3,F3200 AS4428 MAF/PSU,3A

PA0874,PCB ASSY,1931-3-4,F3200 AS4428 MAF/PSU,6A

PA0909,PCB ASSY,1931-111-1,F3200 AS4428 CONTROLLER, NO S/W

RR0917,RESISTOR,PTC,OVERLOAD PROTECT,30V,6A

SF0221,SOFTWARE,F3200 AS4428 CONTROLLER,V3.00,EPROM

SF0222,SOFTWARE,F3200 AS4428 NETWORKED,V3.00,EPROM

SF0224,SOFTWARE,NDU AS4428 NETWORK DISPLAY,V3.00,EPROM

SF0286, SOFTWARE,F3200/NETWORKED/NDU AS4428 CTRLR,V4.02
(Standard, networked and NDU software for AS4428.1 panels with Issue B or higher 1931-111 Controller)

Note 1: Items MEXXXX are intended as factory fit options, but some can be ordered as a standalone item.

ORDERING INFORMATION (CONTINUED)

NEW ZEALAND OPERATION ONLY

A variety of display options are available to satisfy varying NZ requirements. These are covered in detail in Section 5.12. Ordering codes are included for the various components for each option. Major items are as follows:

- | | |
|--------|---|
| PA0499 | PCB ASSY, NZ DISPLAY EXTENDER BOARD
NZ Display Extender Board in standard 16 Zone LED board format. |
| PA0741 | PCB ASSY, PFD 16 ALARM LED DISPLAY, 24V
"Picture Frame" format 16 Zone display board (alarm LEDs only). |
| PA0753 | PCB ASSY, PICTURE FRAME DISPLAY, 16 LED MIMIC, 24V
"Picture Frame" cabinet format board for mimicking 16 Fire LEDs from Display board. |
| PA0483 | PCB, UNPROTECTED TERMINATION BOARD
With a 26 way FRC gives access Display Extender Board inputs and outputs. |
| PA0769 | PCB, UNPROTECTED TERMINATION BOARD, C/W RESISTORS
Version of PA0483 with 3k3 resistor per output for LED current limit. |

CHAPTER 4 CONFIGURING A FIP

4.1

GENERAL

An F3200 FIP is configured to suit a particular customer's requirements by:

Fitting and connecting the required PCB modules;
adjusting or removing links on the PCBs;
programming the FIP.

The detectors, manual call points (MCPs), warning devices, ancillary equipment and field wiring that are connected to the FIP must match the FIP configuration.

The FIP configuration data, which is entered during programming, is stored in the non-volatile memory database. The database may be saved to a computer for backup storage, and reloaded from the computer.

All programmable options have a default option for the most likely usage. That is, for many applications, no programming other than entry of site and zone names will be necessary.

Programming is described in detail in the F3200 AS4428.1 Programming Manual LT0256.

4.2

MODULE CONFIGURATION

The required modules are fitted to the F3200 as described in Section 2.3.2. Note that 8 way modules are connected Bus Out to Bus In, with all 8 Zone Modules preceding any 8 Relay Modules. Where it is desired to add a module to an existing system this can be done by programming the Module Configuration through the keyboard (Refer to LT0256 Programming Manual).

The F3200 does various self-tests on start up and includes checking to see what modules are present (including 16 Zone LED Display Bds). It displays the results on the LCD. If the modules present do not agree with the programmed database then the FIP annunciates this and remains inactive.

E2 Initialisation causes the Controller/Display to accept the modules found as present and stores this configuration in the database. E2 Initialisation also clears all other data programmed in the database.

For servicing, modules can be temporarily removed as detailed in Section 10.2 of the Operator's Manual. This temporary configuration is not stored in the database.

4.3 BATTERY & POWER SUPPLY

4.3.1 GENERAL

The F3200 FIP has a dc power supply, which also serves as battery charger and requires a 24V sealed lead acid battery (i.e. 2 x 12V batteries in series) to be fitted. (See Section 3.3.3 for compatible batteries). Battery leads with 4.8mm Quick Connect receptacles (for connecting to the battery tabs) are included.

Charger Rating (Refer to AS1670.1 Section 8.2).

The standard F3200 has a 3A power supply. Versions are also available with a 6A PSU. This has a second mains transformer, a 3A rectifier PCB and a larger heatsink connected to the MAF/PSU. Several components on the PCB are also upgraded.

When a 6A power supply is fitted, the standard PTC on the MAF/PSU are shorted out and additional battery protection must be fitted (see Section 4.3.5).

To comply with AS1670.1 the power supply rating must be sufficient to charge the batteries while powering the panel with 2 zones in alarm. This includes all remaining quiescent loads, common alarm load, plus 2 (or 20%, which ever is greater) of all connected fire suppression systems in the active state (i.e. solenoids, warning signs, etc).

The definition of charging the batteries is supplying enough current to charge them within 24 hours to provide a capacity that will support 5 hours of FIP quiescent load (i.e. with mains off) followed by 0.5 hour of alarm load for two, worst case zones.

The recommended order of performing calculations is listed in Section 4.3.2.

Battery Rating (Refer to AS1670.1 Section 8.2).

The battery capacity must be sufficient to support 24 hours of quiescent load (i.e. with mains off), followed by 0.5 hour of alarm load for two worse case zones.

Notes

1. The quiescent load includes the FIP electronics (in normal state) plus any external normally energised loads that operate from the battery backed supply. Hence door holders are normally supplied from a non-battery backed supply.
2. Alarm load includes FIP electronics (in alarm state) plus any external loads such as common Warning System, air conditioning shutdown relays, etc, plus the 2 (or 20%) fire suppression zones.
3. The capacity of a battery depends on the rate (i.e. current) at which it is discharged. Most batteries are quoted at a 20 hour discharge e.g. a 10Ahr battery will supply 0.5A for 20 hours. At 3 times the current (i.e. 1.5A) the same battery will discharge in typically 5.6 hours, i.e. the capacity is only 8.5Ahr. At 10 times the rate the capacity is approximately 75% of the 20 hour rate capacity (i.e. 7.5Ahr). Hence for alarm loads it is safest to derate the capacity to 75%.

GENERAL (CONTINUED)

4. The approvals laboratory recommends using 90% derating of batteries used on F3200 because the battery fail voltage (Standby) is 22V instead of 21V (as used on some other FIPs). The local approval body may not require this, however, because although the F3200 will not generate new alarms below the battery fail voltage, it will maintain any alarms and outputs that occurred when the voltage was higher than the battery fail voltage. AS1670.1 does, however, recommend 80% derating of batteries for the effect of ageing, i.e. multiply the required battery capacity (at end of life) by 1.25 when calculating the required capacity for a new battery.
5. For maximum physical battery sizes refer to "Battery Size". (Refer to Section 4.3.4).

4.3.2 BATTERY/CHARGER CALCULATIONS

The recommended order of calculations is as follows:

1. Calculate the FIP quiescent load (I_q) from the figures given in Section 3.3.5. Note that the detector load for each AZC has to be added to the quiescent current per AZC. Calculate I_n separately, where I_n is the external non-alarm, non-battery backed load on the FIP PSU (e.g. door holders).
2. Calculate the FIP alarm load (I_a) for 2 zones in alarm from Section 3.3.5. (Include all external loads e.g. Warning System, relays).
3. Calculate the 5 hour/0.5 hour battery capacity for the charger requirement as follows:
$$\text{Cap (5 hr)} = (5 \times I_q) + (0.5 I_a \times 1.33) \text{ Ahr}$$
$$= 5I_q + 0.66I_a \text{ where}$$
$$I_q = \text{quiescent current}$$
$$I_a = \text{alarm current}$$

Note that the 1.33 multiplier increases the required capacity to allow for an alarm load of up to 10 times the quiescent load (i.e. 75% derating of capacity).

4. Find the greater of $I_q + I_n$, or I_a . Calculate the power supply/charger requirement (I_c) as follows and check that it is less than 3A. (If greater, a 6A charger is required).
$$I_c = I + \text{Cap (5 hr)} \div 24e$$
 where I is the greater of $I_q + I_n$, or I_a , and e is the charging efficiency of the particular battery being used, at the current being used (typically 80%, i.e. $(\text{cap}/24) \times 1.25$).
5. Calculate the battery capacity as follows:
$$\text{Cap (24 hr)} = (24 \times I_q + 0.66 I_a) \times 1.25$$

(See note 4 of Section 4.3.1 regarding the $\times 1.25$ multiplier).

Select a battery which has a rated capacity (i.e. 20 hr rating) equal to or above that just calculated. (Refer to Sections 3.3.3 and 4.3.4 for approved types).

4.3.3 EXAMPLE BATTERY/CHARGER CALCULATIONS

An example FP0781 FIP has the following configuration:

3 8ZMs total (i.e. 2 x FP0553 expansion modules fitted)
1 8RM fitted
20 AZCs enabled, 4 disabled
42mA total detector current on the 20 AZCs
350mA of door holders off +VNBF
5 relays on the 8RM used, with supervision enabled, all switching 24V, 50mA relays, normally de-energised.
Ancillary relay 1 (on the MAF) switching a 24V, 100mA load

EXAMPLE BATTERY/CHARGER CALCULATIONS (CONTINUED)

An external 24V bell drawing 30mA.

A PA0765 T-Gen50 (Tones and Fault Monitoring) with a 16W speaker load.

Calculate the required battery capacity and check the power supply capacity.

Steps

1. The quiescent load (I_q) for the mains fail situation is:
 - 130mA (FIP including one 8ZM)
 - + 82mA (second 8ZM, all AZCs enabled)
 - + 4mA (third 8ZM, basic current only)
 - + 4 x 10mA (third 8ZM, current for 4 AZCs)
 - + 42mA (detector current)
 - + 6mA (8RM, supervision enabled)
 - + 42mA (PA0765 T-Gen with Fault relay enabled)
 - 346mA

Say I_q = 0.35A for mains off.

The quiescent load for mains on is I_q plus the door holders (I_n = 0.35A) i.e. 0.70A. (It was purely coincidence that I_q = I_n).

2. Say, for example, that the 2 zones in alarm can, at most, turn on 3 of the 5 module relays plus the External Bell, the T-Gen Warning System and the Anc 1 load.

The alarm load for 2 zones in alarm is therefore:

- 275mA (FIP including 1 8ZM, 2 zone alarm, MAF relays)
- + 82mA (second 8ZM, quiescent only)
- + 44mA (third 8ZM, quiescent only)
- + 42mA (detector current)
- + 6mA (basic 8RM current)
- + 3 x 11mA (3 relays on 8RM)
- + 3 x 50mA (loads on 3 relays)
- + 100mA (Ancillary 1 relay load)
- + 30mA (Bell load)
- + 704mA (T-Gen50 alarm load of 16/50 x 2.2A).
- 1466mA

Say I_a = 1.47A (the door holders are switched off in alarm).

3. Cap (5 hr) = 5 x 0.35 + 0.66 x 1.47 Ahr = 2.72 Ahr

4. Battery charger current required is:

I_a (1.47A) is greater than I_q + I_n, (0.70A), therefore:

I_c = 1.47A + (2.72/24) x 1.25 = 1.61A (where the 1.25 allows for charging efficiency e of 0.8) i.e. 3A is sufficient.

5. Battery capacity

Cap (24 hr) = [(24 x 0.35) + 0.66 x 1.47] x 1.25 = 11.7Ah. (where the 1.25 allows for battery deterioration over lifetime to 80% of new value).

Two 12V, 12 Ahr sealed batteries from the list in Section 3.3.3. are the smallest batteries that are suitable.

4.3.4 BATTERY SIZE

The maximum battery size given in the specification, Section 3.3.3, of 220mm x 220mm x 175mm, is imposed by the Cardframe, which obstructs insertion and removal of batteries in the bottom of the cabinet.

The maximum sizes which fit within this restriction are:

Century Yuasa	PS-12400	40 Ahr
IRH BB Battery	BP 40-12	40 Ahr
Panasonic	LC-X1242P (AP)	42 Ahr
YHZ Power	GP12400	40 Ahr
Yuasa	NP38-12	38 Ahr

If batteries larger than this are required, then the Cardframe can be made removable by replacing the 3 pop rivets with M4 or M5 screws and nuts.

For an FP0780/782, or an FP0781/783 with a removable Cardframe, the maximum allowable size is 220H x 260W x 175D.

Fitting and removing batteries of this maximum size is difficult, and may require the removal of any modules or brackets fitted in the bottom of the cabinet.

These very large size batteries may also impede the plugging in and removal of modules fitted to the bottom position of the Cardframe.

Battery Combinations

Large capacity batteries can be made up of two parallel sets of 24V batteries of smaller capacities. This allows easier fitting, and allows larger capacities, and a greater range of capacity to be achieved than is possible with a single pair (as indicated above).

4.3.5 BATTERY OVERCURRENT PROTECTION

The MAF/PSU has two parallel PTCs, rated to carry over 3A, for battery overcurrent protection.

Where the Alarm load from the battery to the FIP is greater than 3A (i.e. with mains failed), or where a 6A power supply is used, an external, self-resetting, overcurrent device of suitable rating (greater than 6A, less than 35A e.g. Derwent, 10A Type D (connected to pins 1 and 3)) must be wired between the battery terminals on the MAF/PSU and the battery (see Fig 4.3.2). For this option the PTCs must be shorted by soldering a suitable copper wire between the two adjacent test points +VB and BATT+ (TP11 and TP16 on the MAF/PSU). For a FIP supplied with a 6A PSU, this is done in the factory and the Derwent cut-out is included.

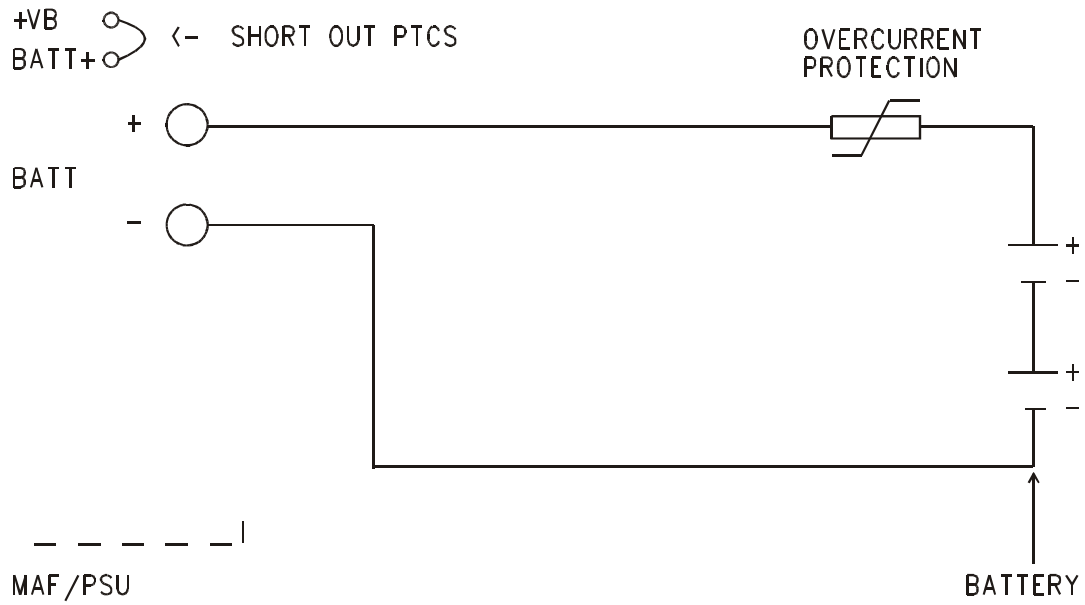

FIG 4.3.2
BATTERY OVERCURRENT PROTECTION FOR LOADS GREATER THAN 3A

4.3.6 POWERING AN F3200 FROM AN EXTERNAL DC SUPPLY

To comply with AS1670.1 F3200 uses a 240Vac supply as the primary power source and back-up batteries as the secondary power source. However the F3200 may be powered from an external dc supply. This must be battery backed, or have another form of secondary source to comply with AS1670.1. The supply must provide a voltage and current within F3200's operating range (preferably 25-27Vdc).

The following wiring instruction connects the dc supply voltage onto the ac (low voltage) input so that the Mains on LEDs on both the MAF/PSU and Controller PCBs are illuminated. Because this signal is not ac, the Controller interprets that as a 'Mains Fail' condition and automatically disables the charger monitoring and automatic battery test, so that the latter does not have to be disabled by programming (but can be if desired).

With no mains (ac) present the real time clock (RTC) on the Controller Display will use the crystal time base instead of mains 50Hz and will therefore not be as accurate.

WIRING

Disconnect the secondary wires of the transformer from the AC IN tabs on the MAF/PSU. Cable tie them safely out of the way (if the mains is not connected they will not be live).

Connect the DC supply –ve to the BATTERY – terminal, and the +ve to the BATTERY + and, if the mains power on LED is to be lit to the J3/1 AC IN tab on the MAF/PSU. This requires a 2mm crimp receptacle (or alternatively may be soldered and preferably covered with sleeving).

If the maximum alarm load can be greater than 3.5A_{dc}, but less than 7A, fit a second PTC (Vigilant part RR0917) to the R43 position on the MAF/PSU (adjacent to the existing PTC, R42). If the alarm load can be greater than 7A then short out the PTCs (connect TP16 to TP11) and fuse the external supply with a sufficient rating to meet the maximum alarm load, but not so high as to not blow on a short circuit or wiring fault.

The +VNBF output (J7A) must not be used.

CURRENT CALCULATIONS

Add an extra 80mA to the stated F3200 quiescent and alarm currents if the connection to the J3/1 AC IN terminal is made.

PROGRAMMING

With a external DC supply the F3200 should be programmed with mains disabled and "Fault after 8 hours of Mains Fail" also disabled.

With default programming, a Battery Low Fault will occur if the supply voltage falls below the specified threshold. This may be disabled by programming. (The installer must consider the requirements for a fault warning at 50% of battery capacity).

4.4 LINKS ON PCB MODULES

4.4.1 CONTROLLER/DISPLAY

Apart from E2INIT (SW1) and DATABASE WRITE PROTECT/ENABLE (Lk7) all links on the Controller Display are factory set. (These configure the PCB for memory chips used, other functions, and type e.g. as a FIP Controller or an RDU Controller).

SW1 and Lk7 are described in LT0256.

4.4.2 MAF/PSU

Of the 4 links on the MAF/PSU, 3 are for field adjustment as follows:

Lk2-Lk4	Bells/ANC 3	-	Fitted in factory to provide switched 24V output. (Bells+, Bells-) to drive the Warning System.
		-	Snip all 3 for clean changeover contacts (NO, COM, NC).

Note that Lk2-Lk4 must remain fitted to provide the required supervision of the Warning System. No links are required for Ancillary Relay 1 and 2 supervision as these have a separate 'Sup' terminal.

One is for factory configuration as follows:

Lk1	Master/RZDU	-	Fitted for Master.
		-	Snipped for RDU (3-wire isolated connection to FIP).

4.4.3 8 RELAY MODULE

The 8 three position links (Lk1-Lk8) select load supervision for each relay.

U <-> unsupervised (voltage free)

S <-> supervised

Note that in addition to setting the Minijump for supervision, supervision must be enabled during programming (default).

4.4.4 16 ZONE LED DISPLAY

The last Display Bd in the chain (i.e. in furthest left position as viewed from the front) requires the Minijump provided to be fitted to Lk1.

CHAPTER 5 INSTALLATION & WIRING

5.1 INSTALLATION

5.1.1 CABINET INSTALLATION

The location of the F3200 FIP is chosen by the Fire Authority and building owner (or owner's representative) in accordance with the Australian Standard AS1670.1.

If the cardframe needs to be made removable to allow fitting/removing of large batteries, this should be done **prior** to cabinet installation. (Refer to Section 5.1.2).

The cabinet is normally fixed to a wall with four 6 mm screws or bolts. The drilling details are shown in Fig 5.1.1.

The following conditions are required:

1. Dry Area, moderate ambient temperature, 45°C absolute maximum.
2. Not exposed to direct sunlight.
3. Not subject to outdoor conditions without suitable protection.
4. The LCD should be at average eye level and must not be higher than 1850 mm or lower than 750 mm above floor level (see Fig 5.1.1).
5. Clear access and viewing for Firefighters and operators.
6. At least 1 metre free space should be provided in front of and on sides of the FIP for installation and maintenance.
7. Must not be installed in hazardous areas as defined in AS3000.
8. If recessed into a wall:
 - i. Allow for the door to open at least 145°.
 - ii. Prevent water entering the cabinet - seal unused knockouts and any top cable entries. Preferably use bottom cable entry, with cables going down 100 mm below cabinet before rising.

It should not be necessary to drill within the cabinet, but if drilling or filing is required, remove the PCBs first. **Clean out all swarf before replacing the PCBs.**

Use antistatic precautions when handling the PCBs.

WARNING

The F3200 is a Class A product. In a domestic environment it may cause radio interference in which case the user may be required to take adequate measures.

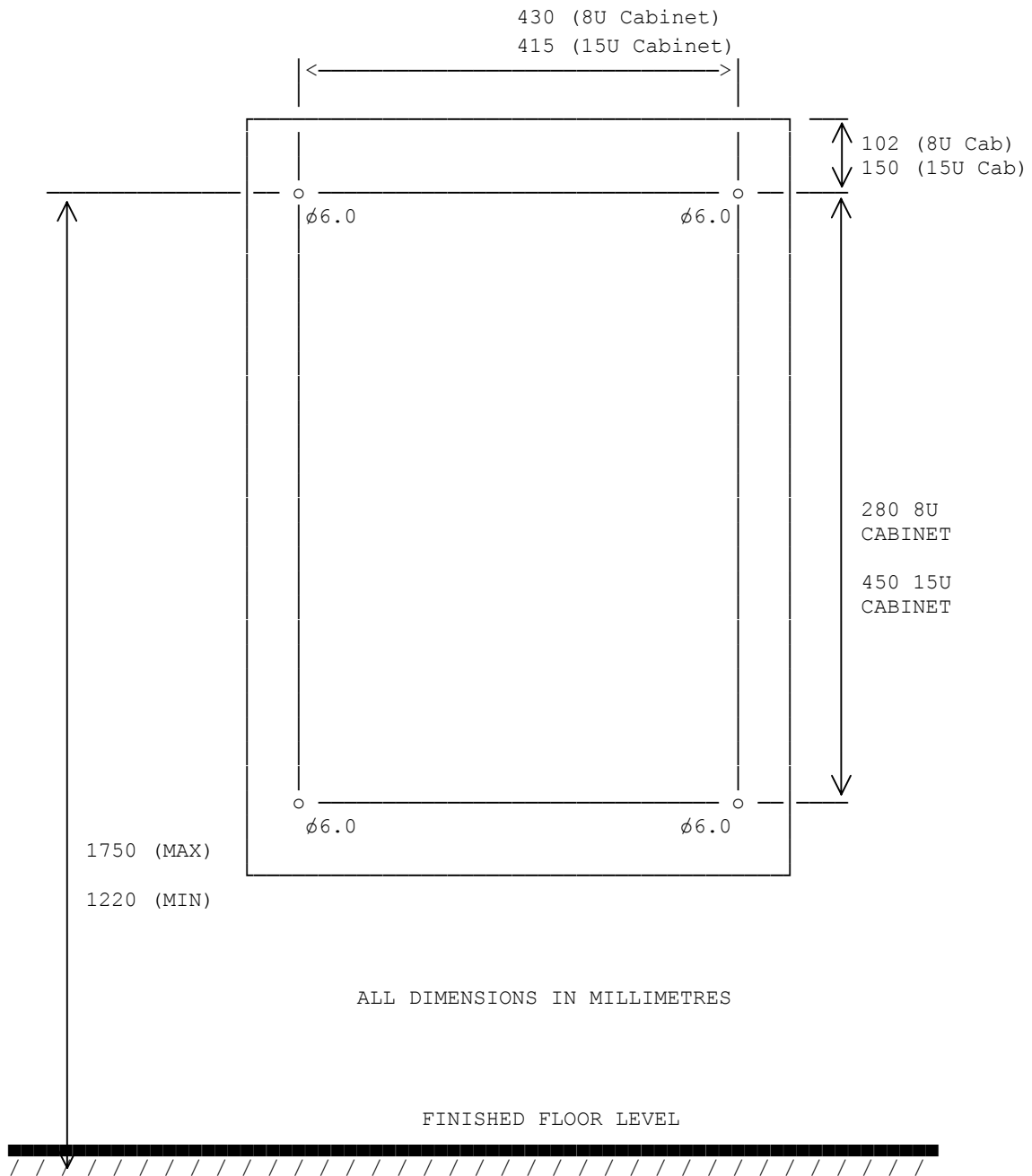

FIG 5.1.1
FIP CABINET MOUNTING DETAILS

5.1.2 CARDFRAME INSTALLATION

A KT0072 Cardframe upgrade kit can be fitted to a 15U F3200 to allow it to take more than three 8 way modules.

1. **If the system does not require large batteries** (refer to Section 4.3.4) it may be fitted as follows, using a pop rivet gun and M4 nut driver. With FIP power not connected, batteries not fitted.
 1. Remove the gear plate.
 2. Remove all 8 way modules.
 3. Remove the 3 sets of PCB standoffs on the left side rear of the plate.
 3. Remove the M4 nuts, washers and PCB spacers from the 3 M4 studs on the left side of the plate.
 4. Fit the Cardframe over the studs with the M3 bushes on the right hand side.
 5. Refit the 3 PCB spacers, washers and nuts on the inside (do not yet fully tighten).
 6. From the plate rear, with the Cardframe firmly against it, insert the 3 pop rivets provided into the holes in the Cardframe, and rivet.
 7. Tighten the M4 nuts on the studs.
 8. Refit the gear plate to the cabinet

2. **If a system requires the Cardframe to be removable to allow the fitting/removing of larger batteries**, then the procedure is similar to that described in 1a above, but, instead of pop rivets, M4 screws should be used as follows:
 1. Use three M4 x 10 or M4 x 12 screws, with nuts, and shakeproof washers.
 2. Fit the screws with the heads to the rear of the gear plate, washers and nuts inside the Cardframe.
 3. Put some Loctite (or equivalent power glue) under the heads of the screws (but **not** on the threads).
 4. Tighten the nuts on the screws initially holding the heads of screws.
 5. Subsequent removal of the nuts (after the Loctite has dried) should be possible without removing the gear plate.

5.1.3 MODULE INSTALLATION

The 8 Zone Modules and any 8 Relay Modules are fitted in order, from top to bottom. The FRCs fit under each PCB, from BUS OUT of the top one to Bus IN of the next one (see Fig 5.1.2).

Observe the following:

- (a) When mounting to the cabinet the M3 mounting screw per module should be tightened firmly to earth the module.
- (b) Modules and FRCs need to be fitted one at a time in the Cardframe. It is easier to start from the bottom module and work up.
- (c) Care should be taken not to scrape an FRC against the bottom of the PCB above it.
- (d) There are redundant slots in the Cardframe to allow for either 6 module even spacing or 8 module even spacing. Choose the correct slots.
- (e) On the Cardframe finger tighten the single M3 screw firmly into the notch in each PCB as this earths the module.

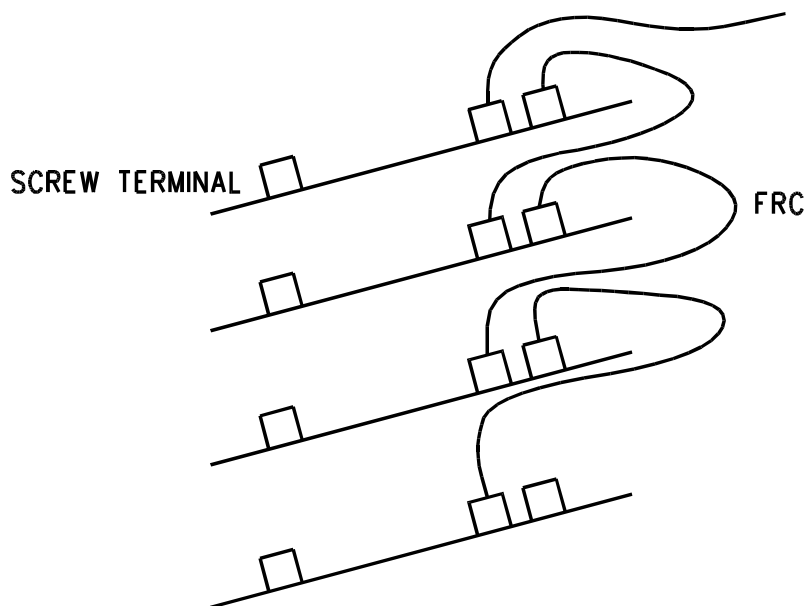

FIG 5.1.2
MODULE CONNECTION WITHIN A CARDFRAME

5.1.4 LED DISPLAY INSTALLATION

When LED Displays are required, the 7U inner door (ME0060) is fitted to the standard cabinet directly below the 4U Operator Display with the M6 screws, washers and cage nuts provided. The hinge is on the right hand side. Click the cage nuts in from the inside. (7U doors cannot be fitted to a small cabinet).

The flat M6 washers have a sharp edge and a rounded edge. Fit washers to the screws with the rounded edge facing the metalwork (to avoid damaging the paint).

The Display Bds mount to the inner door on the standoffs supplied. (FZ3031 for LH position, FP0475 for others, both include the PCB, standoffs, FRC, power leads, diffuser and label master).

Fit the FRCs and Minijump link as shown in Fig 5.1.3.

It is recommended that the LED Display power leads from the MAF/PSU be fitted.

5.1.5 ZONE LABELLING

Zone labelling for the LED Displays can be done simply on a typewriter or word processor.

Note: For a typewriter use a photocopy of the label supplied with the Display Bd.

The **type format** is:

- (a) 6 lines per inch.
- (b) 20 characters at 10 CPI or 24 characters at 12 CPI.
- (c) 2 lines per zone window.
- (d) 1 line between each zone window.

To install the zone naming label:

- (a) Cut the typed label around the border, or cut the word processor sheet to 3mm to the left of the text then 60mm wide and 220mm long.
- (b) Loosen the 4 Phillips-Head screws holding the display window.
- (c) Align zone text with windows.
- (d) Tape top and bottom of zone label.
- (e) Align clear, matt finish, light diffuser with the 3 columns of LED holes (next to the label) with matt side in. Tape in place.
- (f) Tape blank sheets to unused zone window(s).
- (g) Replace display window and fasten the 4 screws.

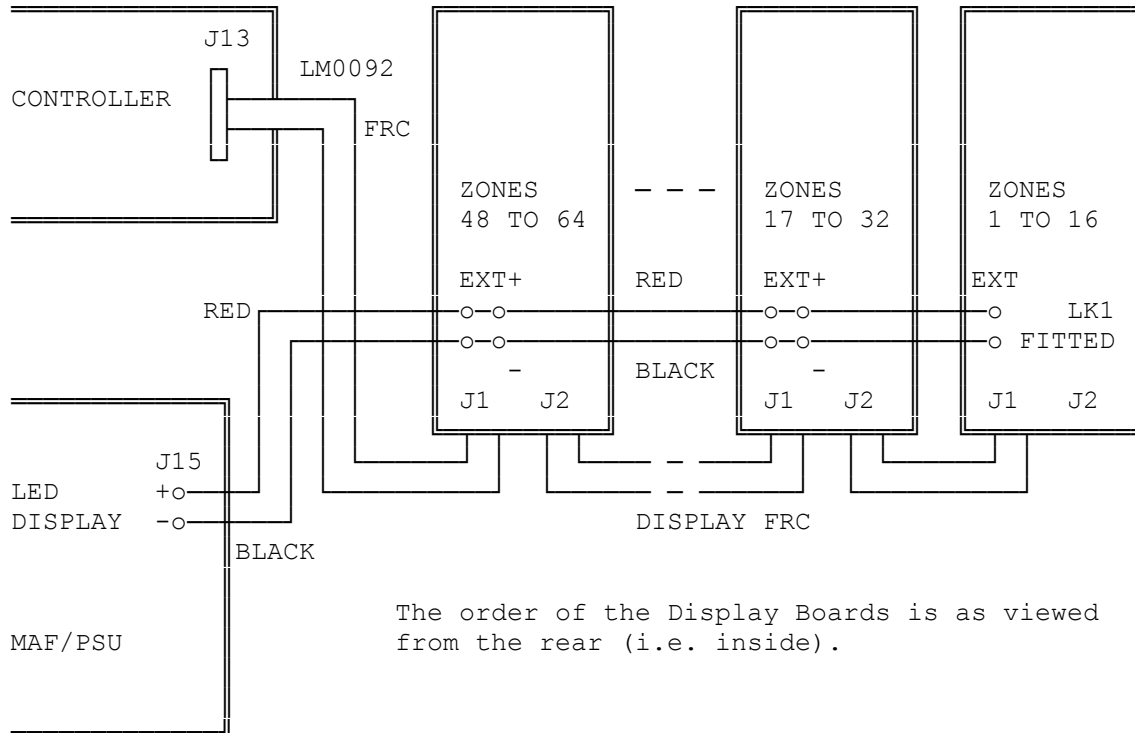

The order of the Display Boards is as viewed from the rear (i.e. inside).

FIG 5.1.3
DISPLAY BOARD CONNECTION

Note that a special loom (LM0092) is required to connect the first Display Board to the Controller Board. This is included in the F3200 LED Display Kit (FZ3031).

For an NDU in New Zealand mode, if a NZ Display Extender board is fitted then it is added to the end of the display board chain after the last 16 zone display board (if any) and link Lk1 on the last 16 zone display board must be NOT fitted. The NZ Display Extender does not need a link fitted to it, its presence indicates to the NDU that it is the last board in the chain. When programming the number of Display Bd, the Display Extender is not counted, but is individually programmed as fitted/not fitted.

The Unprotected Termination board, PA0483, connects to the NZ Display Extender via FRC. The NZ specific wiring connects to this Termination board.

5.2 FIELD WIRING

5.2.1 GENERAL

Cabling should comply with all the points in AS1670.1, Section 8.17. Note the requirements for segregation and identification.

The cabling should, in general, be of not less than 0.75mm² cross sectional area, insulated and have red PVC sheathing. Joins should only occur in enclosed terminal boxes, and it is important that all terminations be good. I.e.

- no bare wire protruding from the terminal;
- no insulation inside the clamp part of the terminal;
- wire not cut or "nicked" during stripping;
- wire not soldered;
- wire not "doubled back" in the demountable terminals with leaf type strain relief clamps;
- all terminals firmly tightened;
- neat service loop;
- goose neck where servicing requires cable movement;
- coil of spare cable in wall/ceiling to allow for mistake/alteration.

Note that it is best to carry out parts of the initial survey during installation, in particular, resistance and insulation testing.

WARNING

Apart from the Mains supply to the FIP, **only ELV cabling should enter the cabinet.**

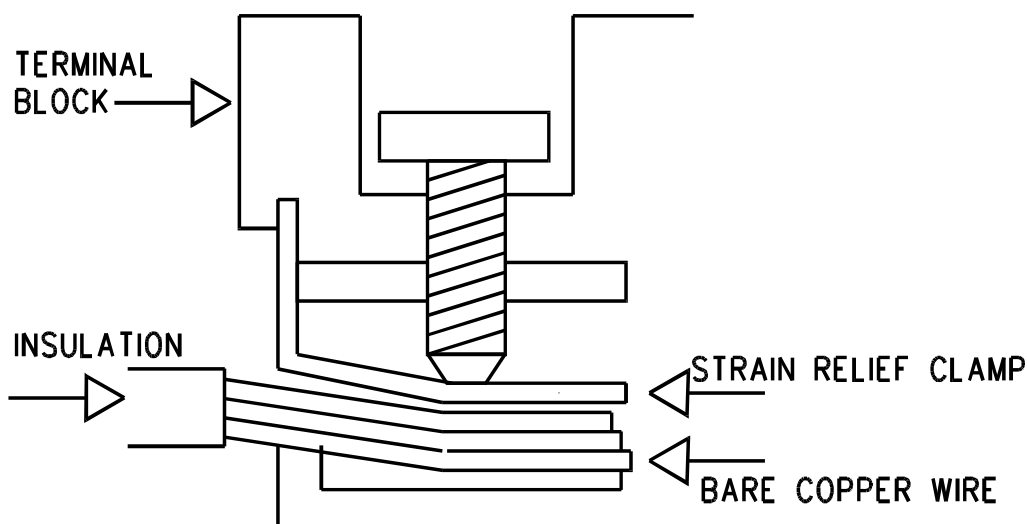

FIG 5.2.1
SCREW TERMINAL CABLE CONNECTION

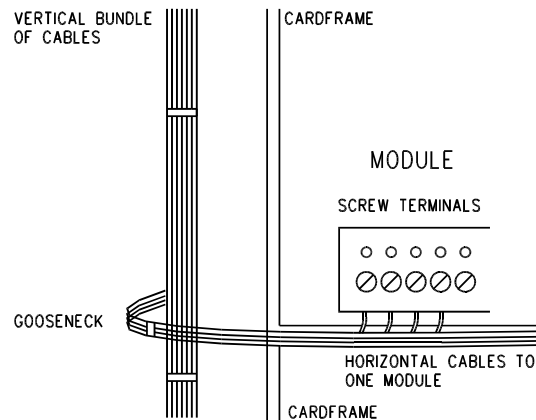

FIG 5.2.2
GOOSENECK CABLING

5.2.2 MAINS WIRING

The mains (240Vac) supply must be connected in accordance with AS1670.1 and AS3000 regulations.

Ensure the mains cables to the FIP are isolated at the Distribution Board before connecting to the FIP.

The mains cable connects to the 3 way terminal block mounted to the cabinet rear behind the mains cover.

- (a) Remove the mains cover with a Pozi screw-driver.
- (b) Shape the mains cable to fit through the grommet in the slot in the top of the cover, cut to length and strip only 20mm of the PVC cable sheath.
- (c) Connect the wires:
 - blue (black) to N
 - brown (red) to A
 - green/yellow (green) to E
 Take care when stripping not to "nick" wires.
- (d) Cable tie the cable to the cabinet.
- (e) Refit the mains cover .

5.3 AZC WIRING

Detectors must be installed and wired as per AS1670.1. Observe the requirements for conductor type and size.

Connection to the particular MCPs, detectors or bases must be as specified by the manufacturer. Similarly for remote LED connection.

AZCs must be wired as per Fig 5.3.1 with "In" of the first detector connected to the 8ZM, and the EOLR to the "out" of the furthest detector.

Examples of illegal wiring are shown in Fig 5.3.3.

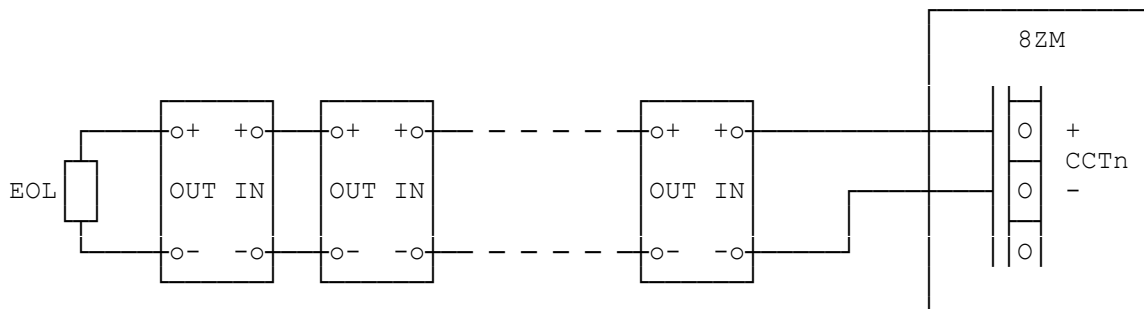

FIG 5.3.1
CORRECT AZC DETECTOR WIRING

The Tyco SU0600 MCP may be used on a circuit that has detectors on it, so that activation of the MCP does not reset the indication on any already activated detector. Wiring of the SU0600 is shown in Fig 5.3.2. The zone must be programmed with B3 = Instant Alarm.

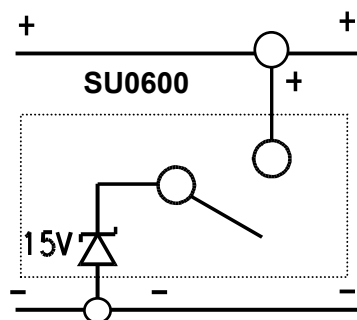

FIG 5.3.2
TYCO SU0600 CONNECTION

Note that a 47 ohm resistor is required between the F3200's AZC +ve terminal and the detector circuit when any T614 (Mk1), 4098-9618EA, 4098-9619EA or 4098-9621EA heat detectors are present on the circuit (refer PBG0116).

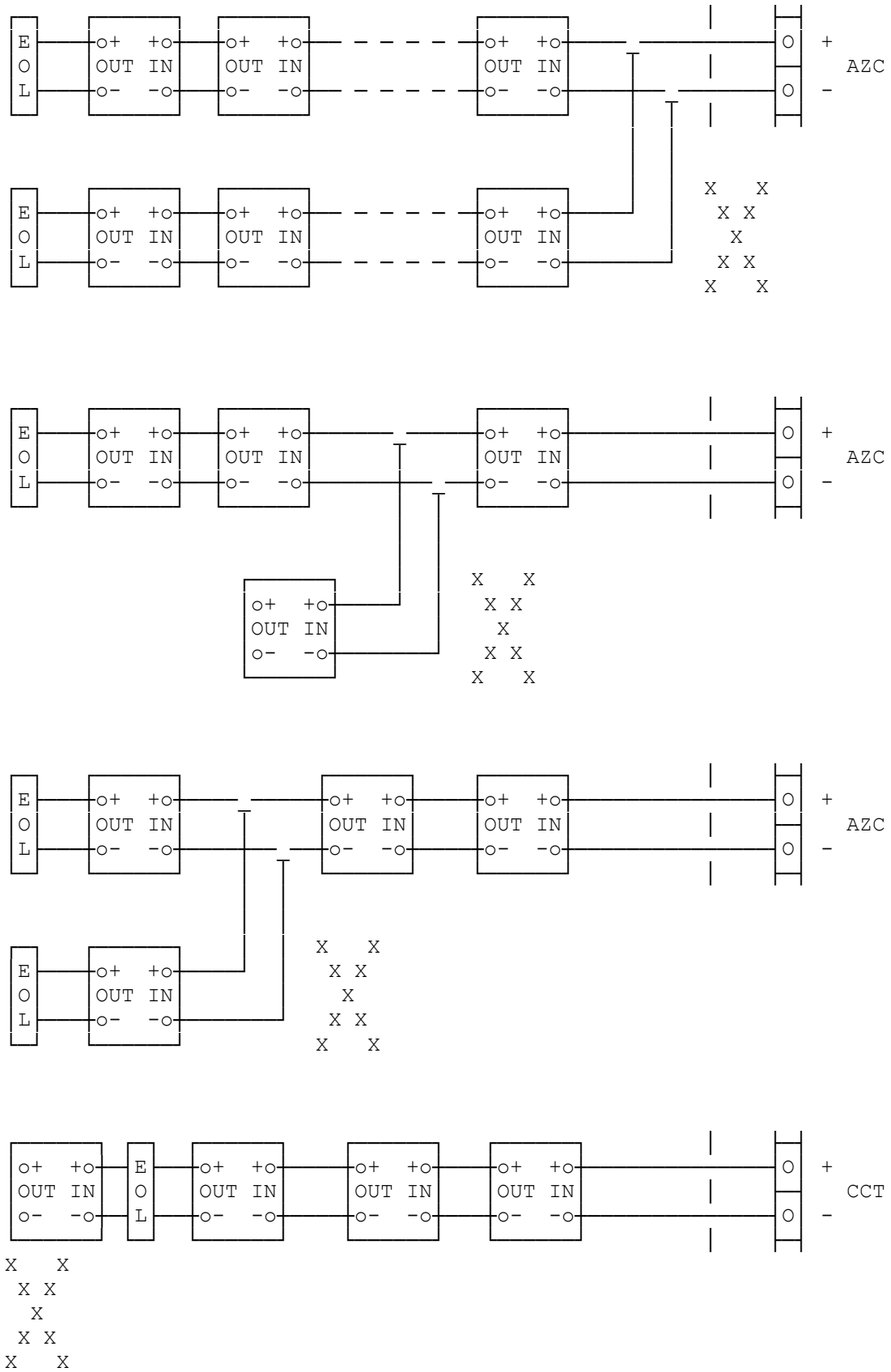

FIG 5.3.3
EXAMPLES OF INCORRECT AZC WIRING

5.4 MAF ANCILLARY RELAY WIRING

The original (AS1603.4) F3200 has a single Warning System output and Isolate Switch, namely the Anc3/Bells relay, configured as Bell+/-, and the "Bells Isolate" key. It is now typical for FIPs to control two outputs, i.e. a single External Bell (or Strobe), and a separate building Warning System that produces tones to AS2220 or ISO8201.

The MAF module has 3 Ancillary Relays. Typically, Anc 1 is used for door holders, air-conditioning shutdown etc; Anc 2 is used for the External Bell; and Anc 3/Bells is used for the Warning System. Wiring of the External Bell should be as per Fig 5.4.2 using Anc 2. The Warning System is covered in Section 5.5. Anc 1 and Anc 2 each have 1 set of voltage free contacts available on screw terminals, and a second set to which the screw terminals are not fitted as standard. Where supervision of wiring is required, the supervision (SUP) input is used as shown in the following figures.

Door Holder Wiring

Door holders are typically powered through normally closed contacts from the non-battery backed supply (+VNBF). As door holders are inductive, a suppression diode should be fitted between 0V and the door holder positive line.

Where door holders have individual manual release buttons, suppression should be fitted at each device.

Observe polarity, the cathode of the suppression diode is connected to the positive line.

Where supervision is required, the recommended connection is as shown in Fig 5.4.1 A or B with a return from the furthest door holder. The alternative shown in Fig 5.4.1 A does not supervise the loop.

The 24V relay used at the end of the loop in Fig 5.4.1 B only needs to switch low current.

"Door Holder" mode supervision "looks for" the presence of voltage when the ancillary relay is de-energised.

Plant Relay/Solenoid Wiring

Where a plant relay is to be energised on Ancillary Relay operation it would typically be powered through normally open contacts from a battery-backed supply.

If wiring supervision is required, it is connected as shown in Fig 5.4.2. "Load" mode supervision looks for a resistance to 0V when the ancillary relay is de-energised. For a very low resistance load (ref Specifications Section 3.4.2) a series diode must be fitted as shown.

Heavy Load Wiring

If a load greater than 2A resistive (1A dc inductive) needs to be controlled by F3200 then this can be achieved with the addition of a 24V Bell Monitor Board (PA0494). This can switch up to 5A dc (resistive) and supervises the load wiring for open and short circuit faults.

Further details for the Bell Monitor Board are contained in LT0190. A representative wiring diagram is shown in Figure 5.4.3. If the load exceeds 2A dc then the power connection must be taken off +VBF2 or directly off the battery terminals via a suitable fuse (but not the +VBF1 terminal). The fuse and wiring are supervised by the Bell Monitor Board, as it will generate a fault if power to it fails.

WARNING

Apart from the mains supply to the FIP only ELV wiring may enter the cabinet.
Relays must not be used to directly switch medium or high voltage.

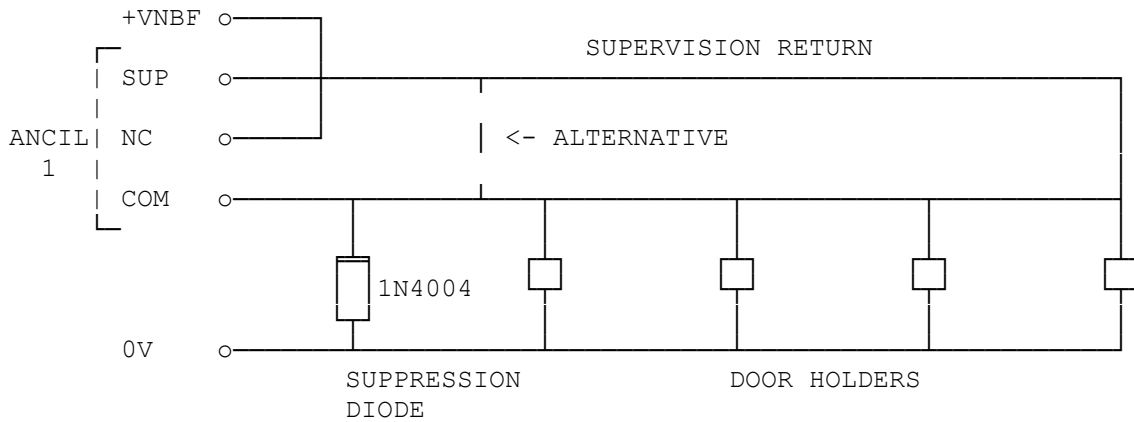

A. WITH SUPERVISION OF LOOP POSITIVE WIRING ONLY

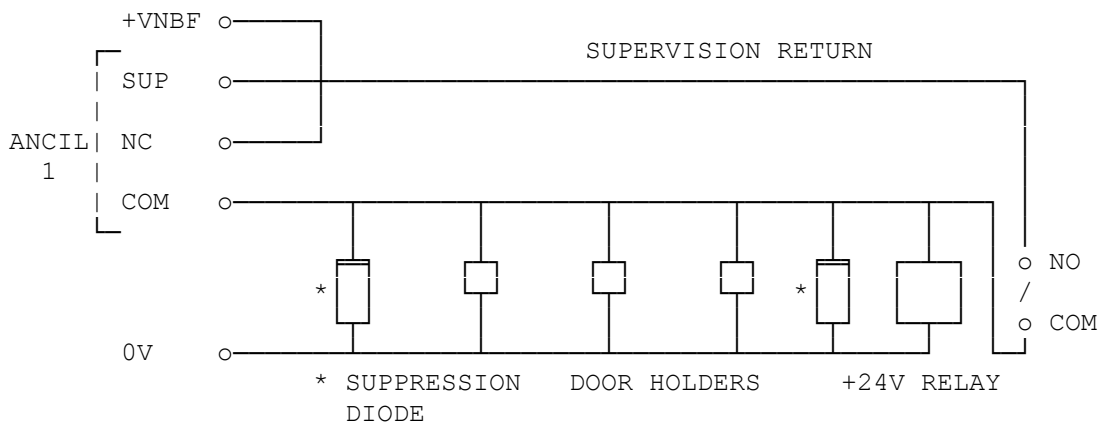

B. WITH SUPERVISION OF LOOP POSITIVE AND NEGATIVE WIRING

FIG 5.4.1
EXAMPLE OF DOOR HOLDER WIRING WITH SUPERVISION

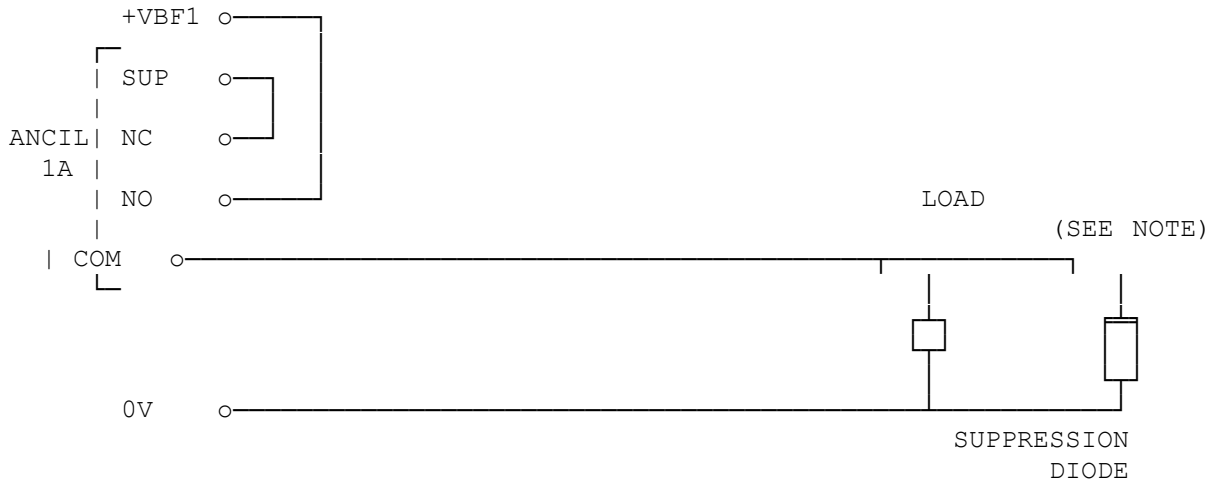

Note: For a load of less than 400 Ohms a diode of suitable current rating must be added in series with the load at the load as shown below.

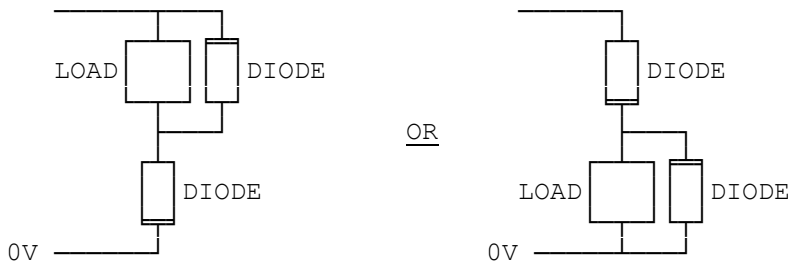

FIG 5.4.2
EXAMPLE OF PLANT RELAY WIRING WITH SUPERVISION

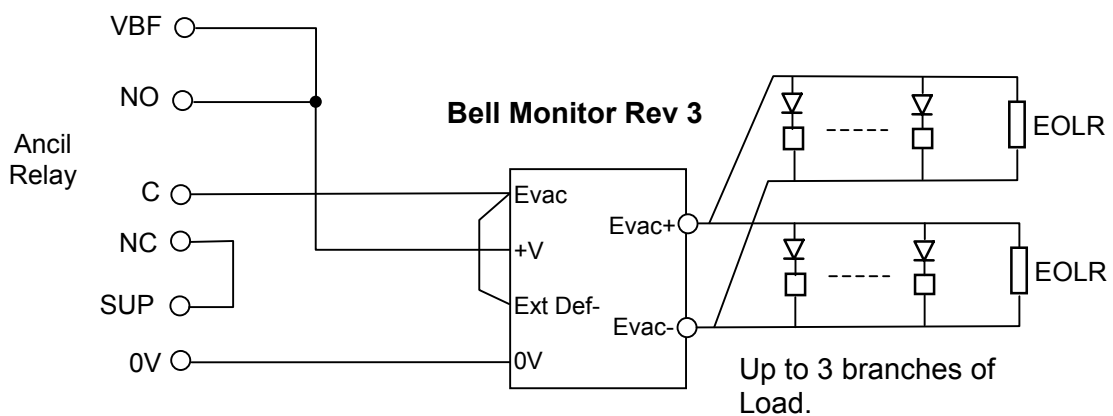

FIGURE 5.4.3
EXAMPLE OF SUPERVISING MULTIPLE BRANCHES OF MULTIPLE LOADS

5.5 WARNING SYSTEM WIRING

The typical configuration allocates the Ancil 3/Bells relay to drive the Warning System, and has links Lk2-4 fitted so that a switched 24V output is available at the +/- terminals. The supervision allows for up to 3 branches of wiring, with each requiring its own end of line resistor (EOLR). The value of the EOLR varies with the number of branches such that the combined total is always 3K3. The EOLR must be fitted at the end of each branch.

<u>Branches</u>	<u>EOLR</u>
1	3k3
2	6k8
3	10k

The Ancil 3/Bells output can be used to directly control alerting devices such as sounders (that generate tones to AS2220 or ISO8201), AVIs, strobes etc. If each device does not have an internal series diode then a series diode must be fitted at each device, as shown in Fig 5.5.1. The diode must be rated to carry the current of the device.

The AVI Mk2 includes a series diode and multiple units can be connected to a common line, be supervised, and have the synchronisation wire inter-connected. Note the original AVI (FP0628) requires an external series diode to be fitted at each device for a supervised circuit. Multiple original AVIs cannot be synchronised because the sync line carries the signal and is not supervised.

The Bells +/- output is limited to 2A dc resistive max. (Note that loads such as AVIs, Mini-Gens are considered resistive, whereas loads such as Solenoids and bells are inductive). A load of up to 5A dc resistive can be accommodated by use of a Bell Monitor Board and a separate, 6A dc, inline fuse. See Fig 5.5.6.

A relay on an 8 Relay Module can also be used to control and supervise a circuit of evacuation devices. This is shown in Figure 5.5.3. Note that both poles of the relay are needed and the relay needs to be programmed so that it doesn't supervise the wiring when it is activated (requires V2.09 or greater software). Although shown with only 1 circuit of evacuation wiring, it can actually support two branches, using a 27k EOL resistor on each.

The Ancil 3/Bells relay can also be used to activate (and supervise) external tone generation devices such as Mini-Gen, T-GEN, Microvac and QE90 this is covered in following sections.

MINI-GEN

The Mini-Gen has an internal diode and can be connected with up to three branches of speakers as per the instructions included with each unit. The 10k EOLR fitted to each speaker line must be rated at 2W and is supplied with the unit. Refer Fig 5.5.2. If less than 3 branches are required, 10K 2W is still fitted to the end of each branch, with the other EOLRs being fitted to the +/- dc input terminals of the furthest Mini-Gen. Refer to the instructions.

The Mini-Gen can be link selected to produce an Alert tone, an Evac tone, an automatic change from Alert to Evac after 1 minute, or an automatic change after 3 minutes. If desired, it can be configured to produce Evac, with a relay switching the tone to Alert. For this, a mini-jumper is fitted to link V, and the supplied 3 way connector fitted to link A/B with normally closed relay contacts shorting pin 2 to 3 (position B) to produce Alert. When the contacts open, the tone will change to Evac. Note that this applies only to Mini-Gen Rev 3 bds with V2.00 or greater software, and for internal wiring of the relay to the Mini-Gen (i.e. the Mini-Gen must be mounted within, or adjacent to the FIP.)

T-GEN 50

The T-GEN 50 is permanently powered, requiring a supervised Alarm- signal from the FIP rather than switched power. The BELLS- terminal can be used for this, refer Figure 5.5.7. Alternatively, an Ancil relay on the MAF, or an 8RM relay can be used as per Sections 3.4 and 3.5 of the T-GEN Installation Instructions, LT0186.

Note that a 2k5 ELD (3k3 and 10k 1% in parallel) must be used for the BELLS relay, when connecting to the ALM- input on T-GEN. Configure the T-GEN to NOT supervise its ALM- input (SW4 off).

Alternatively, an open collector output could be used, but the T-GEN will need to supervise its ALM input and be fault supervised via an unused F3200 circuit input.

MICROVAC AND QE90

The Anc 3/Bells output can be used to activate a Microvac/QE90 and to supervise the link for a fault condition. A 24V relay (e.g. PA0730 General Purpose Relay Bd) is required to be mounted within the Microvac/QE90, and the wiring as shown in Fig 5.5.4.

Alternatively the Anc 3/Bells output can be made voltage-free (remove Lks 2, 3, 4 on the MAF) and a spare 8 Zone Input can be used to supervise the Microvac/QE90. This arrangement, shown in Fig 5.5.5, does away with the relay, but requires a 4-wire connection and one spare input. The input should be programmed as a status-only zone and the fault state included in the logic equation to generate a Warning System fault. E.g. for zone 16 WSF = Z16F.

A high level link can be achieved between the F3200 and QE90 using the RZDU communications output. This is only suitable for when the F3200 and QE90 are co-located, as there is no duplication of the cable. Details for this wiring are contained in the QE90 Installation and Commissioning Manual LT0088. In addition, the QE90 needs to be supervised for a fault condition. This can be done as shown in Fig 5.5.5 using a spare zone input or as in 5.5.4 using the Ancil 3/Bells output supervision.

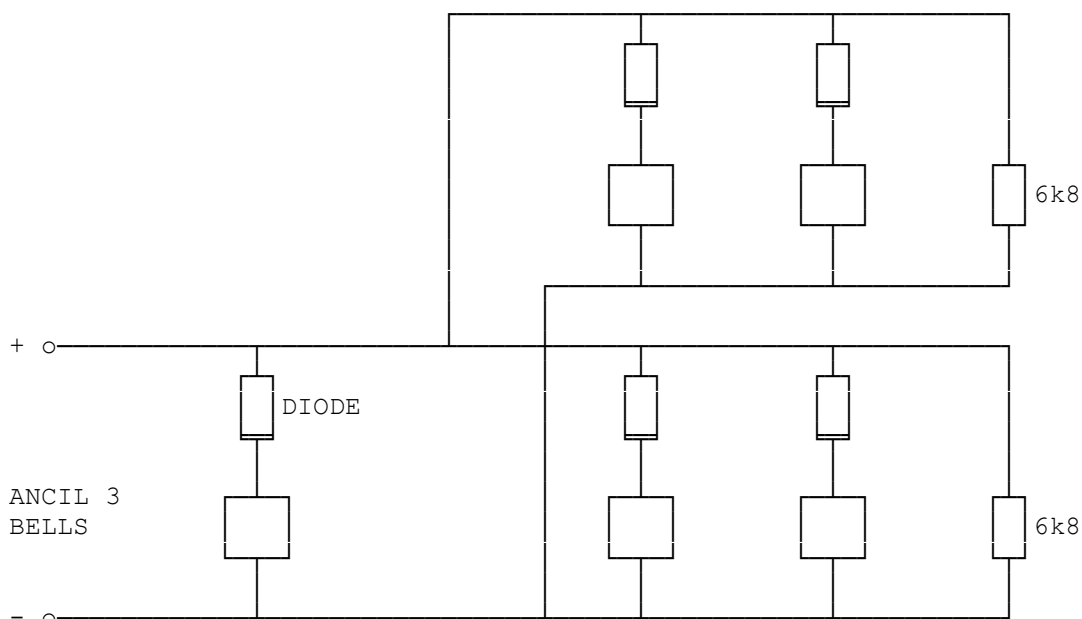

FIG 5.5.1
EXAMPLE OF WIRING WITH 2 SUPERVISED BRANCHES
FOR DEVICES WITH NO INTERNAL SERIES DIODE

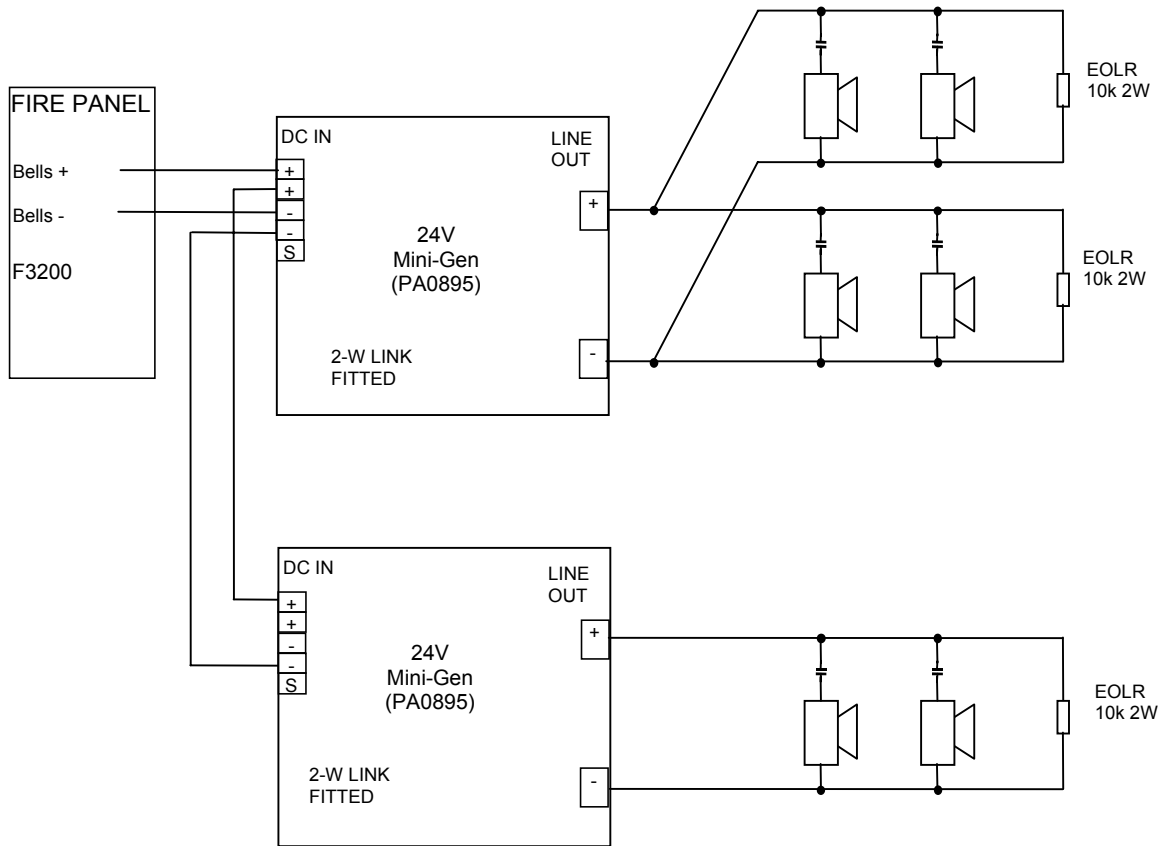
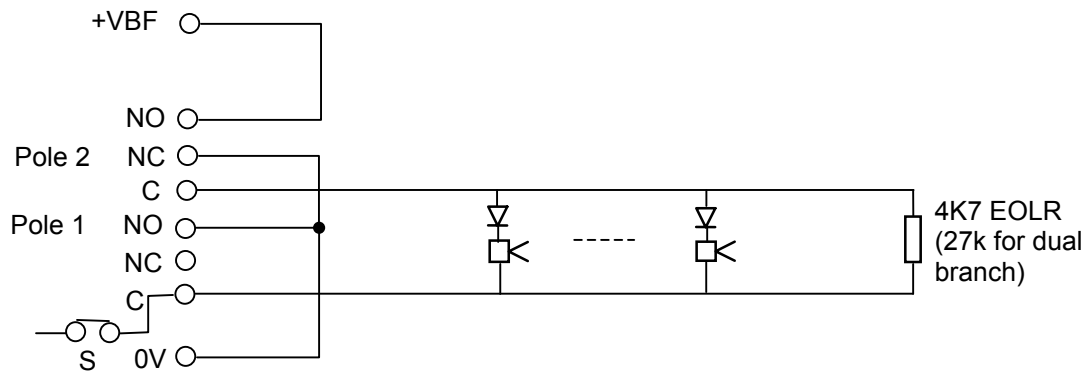

FIG 5.5.2
EXAMPLE OF MULTIPLE MINI-GENS WITH 3 BRANCHES OF SPEAKERS



Note that this configuration requires that the relay confirmation (ACT) be disabled.

FIG 5.5.3
EXAMPLE OF A SUPERVISED EVAC CCT USING 2 POLES OF AN 8RM RELAY

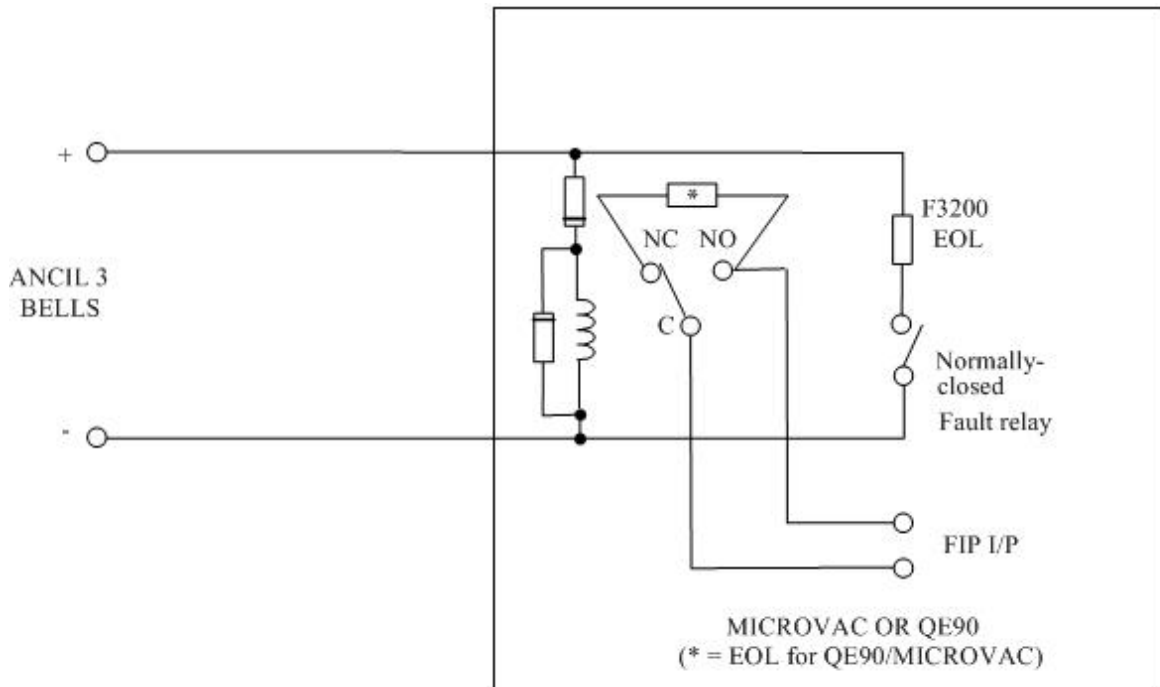

FIG 5.5.4
WIRING ANCIL 3 TO MICROVAC/QE90

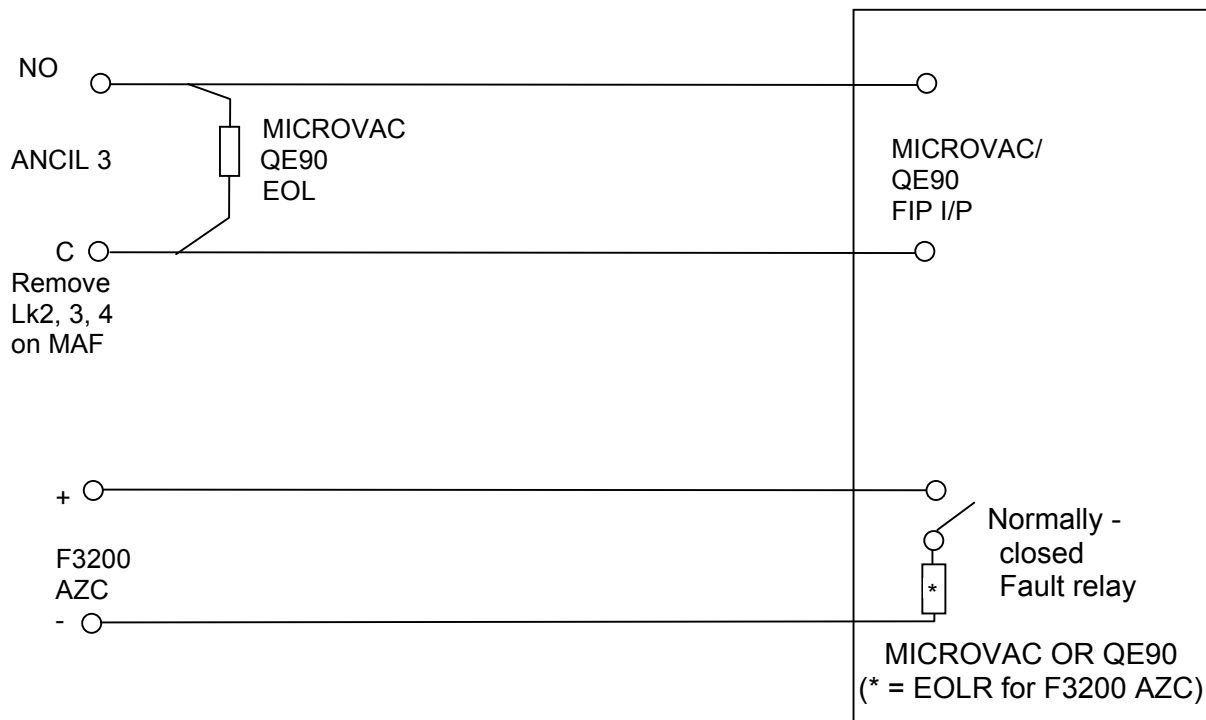
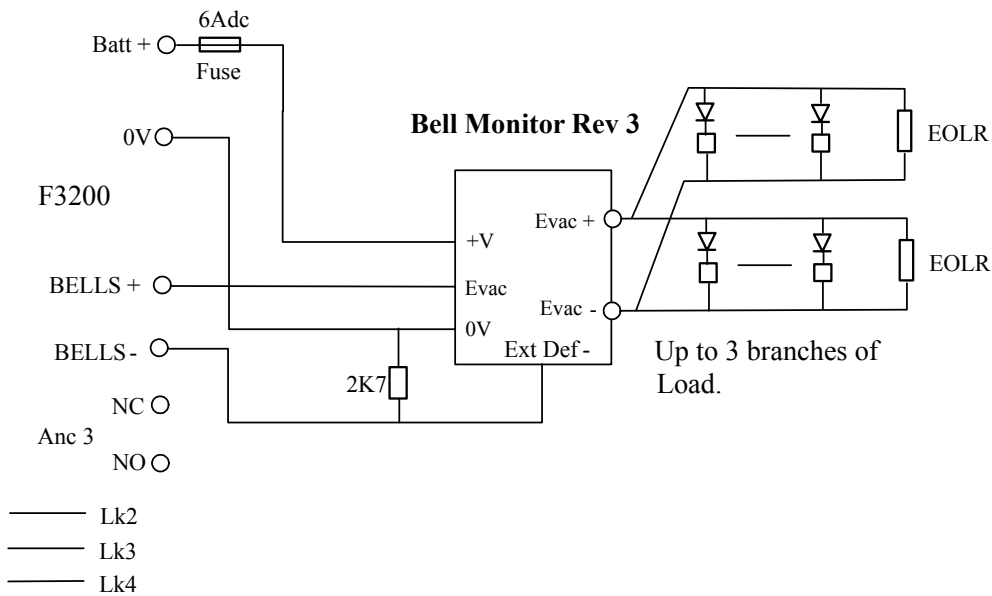

FIG 5.5.5
WIRING ANCIL 3 AND 8ZM INPUT TO MICROVAC/QE90



Notes

1. Wire an in-line fuse holder with 6A fuse from Batt+.
2. The Bell Monitor must be Rev 3 or greater and is supplied with instructions, adhesive based stand-offs, and EOLRs.

**FIGURE 5.5.6
USING BELL MONITOR BOARD ON ANCIL 3/BELLS RELAY**

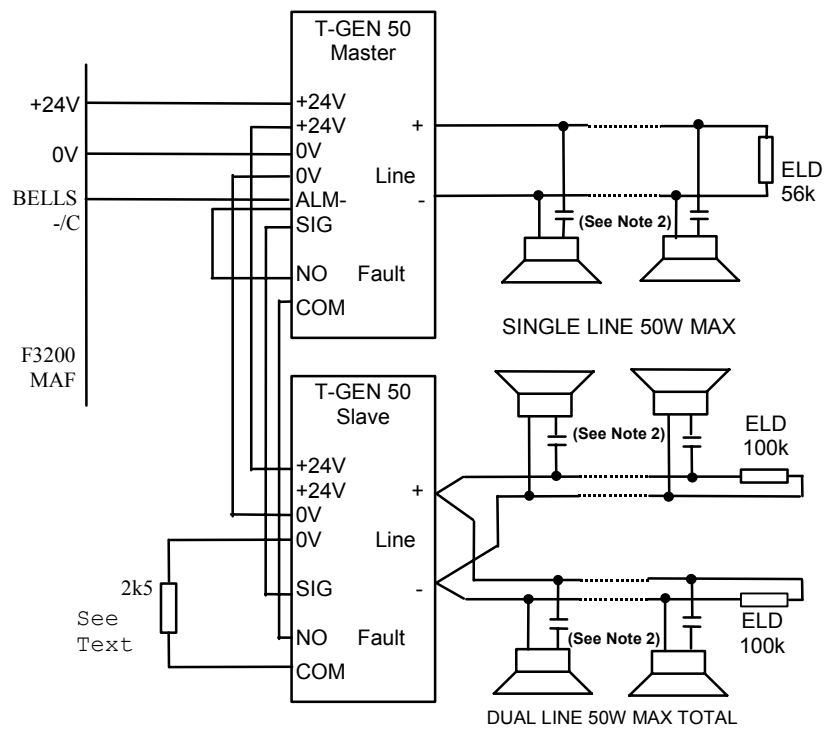

**FIGURE 5.5.7
WIRING T-GEN TO F3200 BELLS/ANC 3 RELAY**

5.6 MODULE RELAY WIRING

The 8 Relay Module relays each have one set of voltage free change-over contacts (ie one pole) accessible via screw terminals, to switch plant equipment. The second pole of each relay can be accessed by fitting a 3-way de-mountable connector block pair CN0488 and CN0206.

There are two sets of four inter-connected, voltage free, looping terminals per module that can be used for looping supplies onto relays or loads.

If the load switched is inductive e.g. a solenoid coil, a suppression diode must be fitted as shown in Fig 5.6.1.

Supervision

Supervision of the field wiring from the FIP to the load is shown in Fig 5.6.1. This only works for a single load, or multiple co-located loads wired in parallel (though for multiple co-located loads, the supervision will not detect a fault if one load becomes disconnected). It requires the load or an EOLR to be connected between the relay COM terminal and the FIP 0V, and the supervision link on the module to be fitted in the "S" position. If the COM output does not 'see' a supply voltage or open circuit when the relay is activated (requires V2.09 or greater software, then the relay must be programmed to not supervise the load when activated).

An example of supervising a circuit of multiple, separately located loads using 2 poles of one relay is shown in Fig 5.5.3.

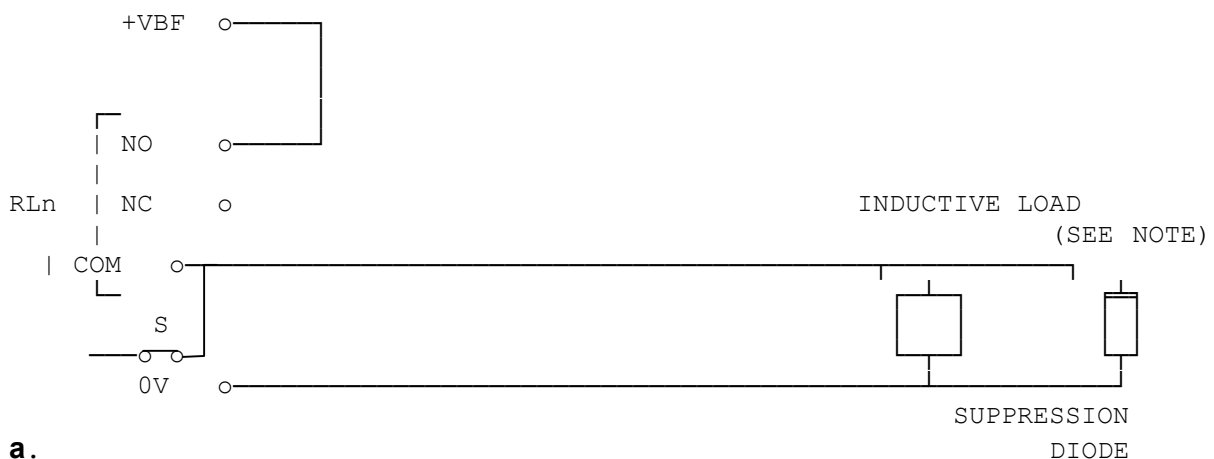

Note: For a load of less than 400 Ohms a diode of suitable current rating must be wired in series with the load at the load as shown in b. below.

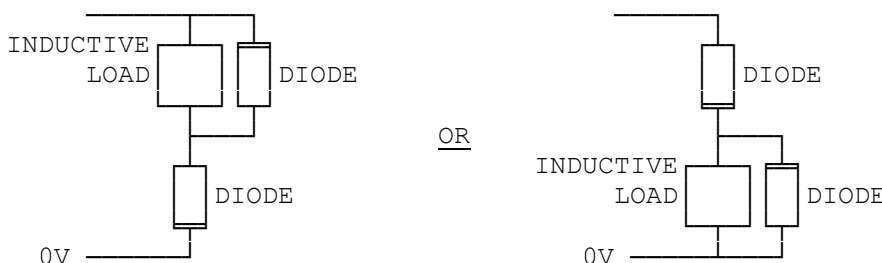

FIG 5.6.1
EXAMPLES OF MODULE RELAY WIRING WITH SUPERVISION

5.6.1 DUAL POLE – POLARITY REVERSAL OUTPUT

Two relays; or 1 relay, an open collector output and an external 2 pole relay (e.g. PA0730); can be arranged to provide a supervised dual-polarity output suitable for driving dual strobes (Alert and Evacuate) or some visual warning devices (e.g. an AVI). The output is normally off (supervising voltage only), but can turn on with 24V in one polarity or in the other polarity. This is shown in Figure 5.6.2.

If the dual pole relay is a second 8RM relay then the additional connector blocks need to be fitted (CN0260 and CN0488). Supervision is not enabled on this relay. The supervision on the other relay will detect any short circuit, but may not detect an open circuit with multiple sets of strobes/AVIs. This will depend on the type of strobe/AVI and the quantity remaining connected.

The relay should be programmed to operate when either strobe is required, and the open collector output (or 2nd relay) is programmed to operate for Evacuate.

Note that many strobes have a large capacitor inside them that causes a large in-rush current at power on. Therefore it may be necessary to add some series resistance if the cable length to the first set of strobes is not enough to limit the current. Add 10-20 ohms for a total strobe current of <100mA, 8-10 ohms for 100mA, and 2 x RR1007 NTCs in series for 300mA-1A.

Further details are contained in PBG0072A for using this to control a T-Gen as well, or to include an Auto/Isolate switch that can activate the strobes as well as the T-Gen.

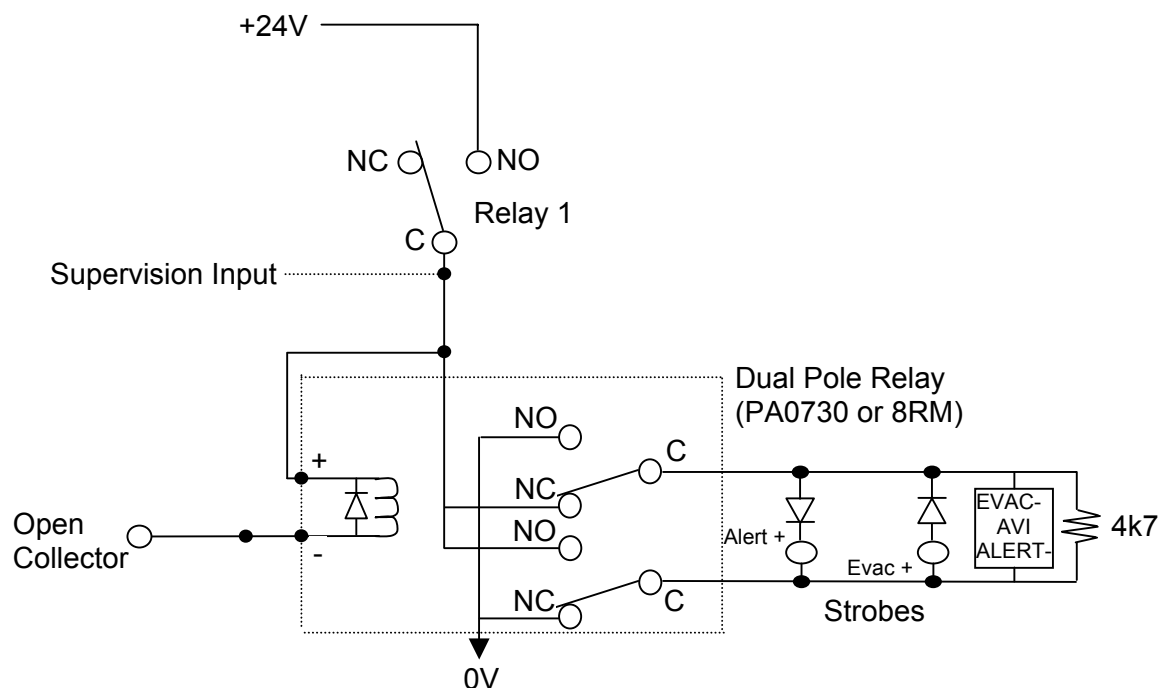

FIGURE 5.6.2
DUAL POLARITY OUTPUT FOR STROBES/AVI

5.7 OPEN COLLECTOR WIRING

5.7.1 LED MIMIC DISPLAYS

It is expected that the most common use the open collector outputs will be to switch LEDs on "mimic" displays. These outputs are approved for field connection, so may be used to "drive" remote mimics. Typical connection is shown in Fig 5.7.1.

5.7.2 INTERFACING TO OTHER EQUIPMENT

Where the open collector outputs are used to switch inputs to other systems, such as an Evacuation System or Plant Computer, there are two main options as follows:

1. Direct Coupling

The open collector output switches the equipment input to less than 1V (typically 0.6V at 1mA). E.g. it may be used to switch a 5V CMOS input, or monitored 5V, 12V or 20V input. Refer to Fig 5.7.2.

Note that for this to work, the 0V supply of the equipment must be connected to the 0V supply of the FIP. This may not be desired, especially if the equipment has a power supply connection to earth.

Note also that the open collector output has protection diodes to the FIP positive and negative supplies and should not be connected to inputs that could be "pulled" to a voltage above or below these supplies, even with mains failed and battery voltage low.

2. Isolated Coupling

The open collector output can be used to switch a relay, or an optocoupler as shown in Fig 5.7.3. When the open collector is "on", the optocoupler transistor is also "on".

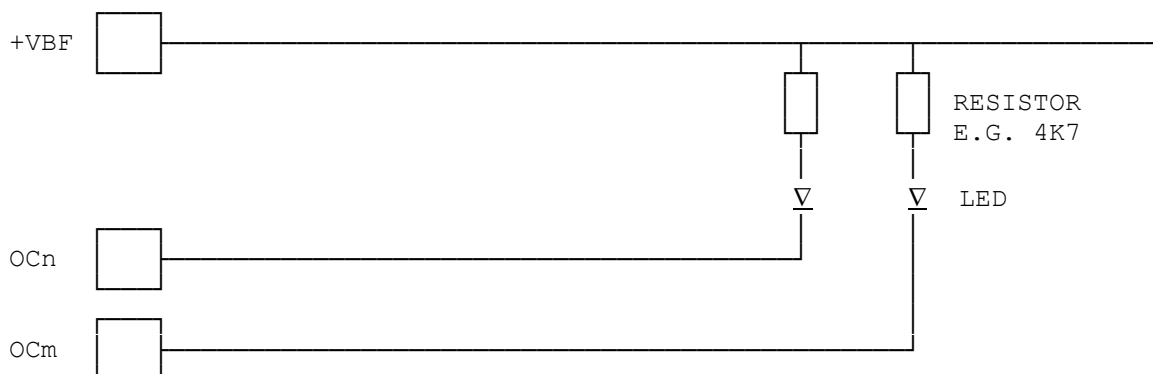

FIG 5.7.1
EXAMPLE OF LED MIMIC WIRING

Further details are contained in PBG0072A for using this to control a T-Gen as well, or to include an Auto/Isolate switch that can activate the strobes as well as the T-Gen.

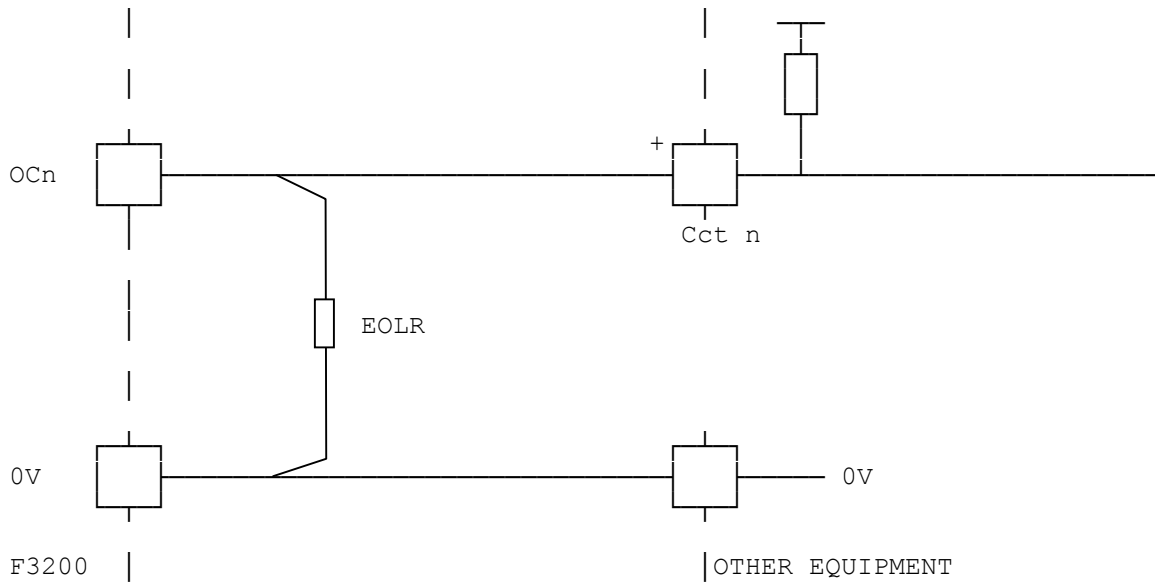

FIG 5.7.2
EXAMPLE OF INTERFACING TO OTHER EQUIPMENT, DIRECT COUPLING

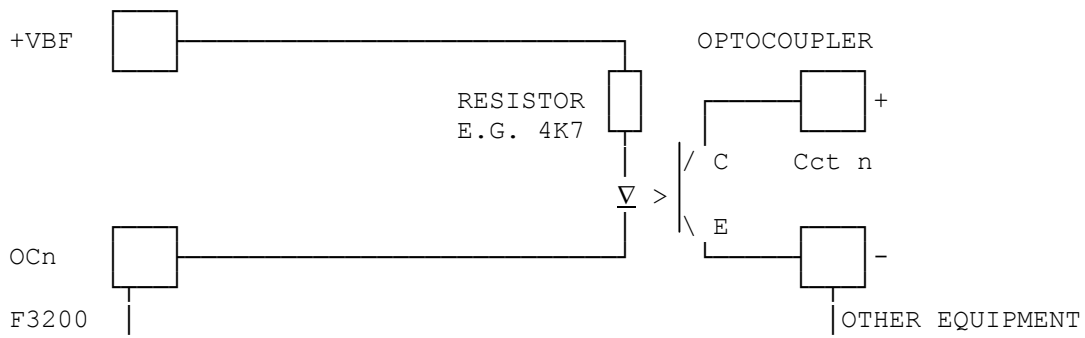

FIG 5.7.3
EXAMPLE OF INTERFACING TO OTHER EQUIPMENT, OPTICAL ISOLATION

5.8 ASE INSTALLATION AND WIRING

A Centaur ASE may be mounted in an F3200 panel or an NDU in a large cabinet. Two kits are available, namely KT0199 and KT0212. Both are 3U hinged front panels accommodating 1 or 2 ASE or V-Modem units (or a combination) respectively. The kits include mounting parts and fitting instructions.

The ASE should be wired directly off the battery via its own fuse. Wiring of the ASE FP0740 EOL unit is as per the ASE installation instructions. The red wires are wired across the MAF Alarm relay NC and C terminals, the yellow wires across the MAF Fault relay NC and C terminals, and the blue wires across the MAF Isolate relay NC and C terminals. No other connections to these relays are permitted when the ASE EOL unit is used.

Locating the ASE remote from the panel has additional requirements under AS4428.1 (Clause 2.10) that currently cannot be met.

5.9**RDU WIRING**

A FIP may drive up to 8 Remote Display Units (RDUs) that are programmed to send information back to the FIP. More "monitoring only" devices may be connected to the FIP RZDU Tx line. Some RDUs have their own power, but others require their power (24Vdc) to be supplied from the FIP or an approved PSU with battery backup.

The RDUs are all connected in parallel on common Tx and Rx circuits. Star and Bus wiring connections are permitted as shown in Fig 5.8.1.

NOTE: TX from the FIP goes to RX on ALL RDUs

RX from the FIP goes to TX on ALL RDUs

Fig 5.8.1 shows an example of interconnection between both MAF and Non-MAF configured RDU(s) and the FIP.

NOTES: To maintain electrical isolation:

- (1) Lk1 on the MAF/PSU Board should be cut for RDUs with their own MAF/PSU module.
- (2) Non-MAF configured RDUs that are powered by a PSU other than the FIP must have Lk3 on the Remote Termination Board cut and Lk14 on the Controller in the "R" position.

Cable Limitations

The maximum distance to the furthest RDU is determined by the cable type used and the wiring arrangement.

- (1) The MAXIMUM line resistance loop (FIP TX out, 0V return must not be greater than 150 Ω .
- (2) The MAXIMUM inter-wire capacitance at the FIP RZDU terminals MUST NOT exceed 100 nF. This must be the total of all cables used - not just the length to the furthest RDU. Typically this is 1km of TPS cabling.
- (3) The +V and 0V cables must be of sufficient size to avoid excessive voltage drops to RDUs when they are drawing maximum current (e.g. lamp test).

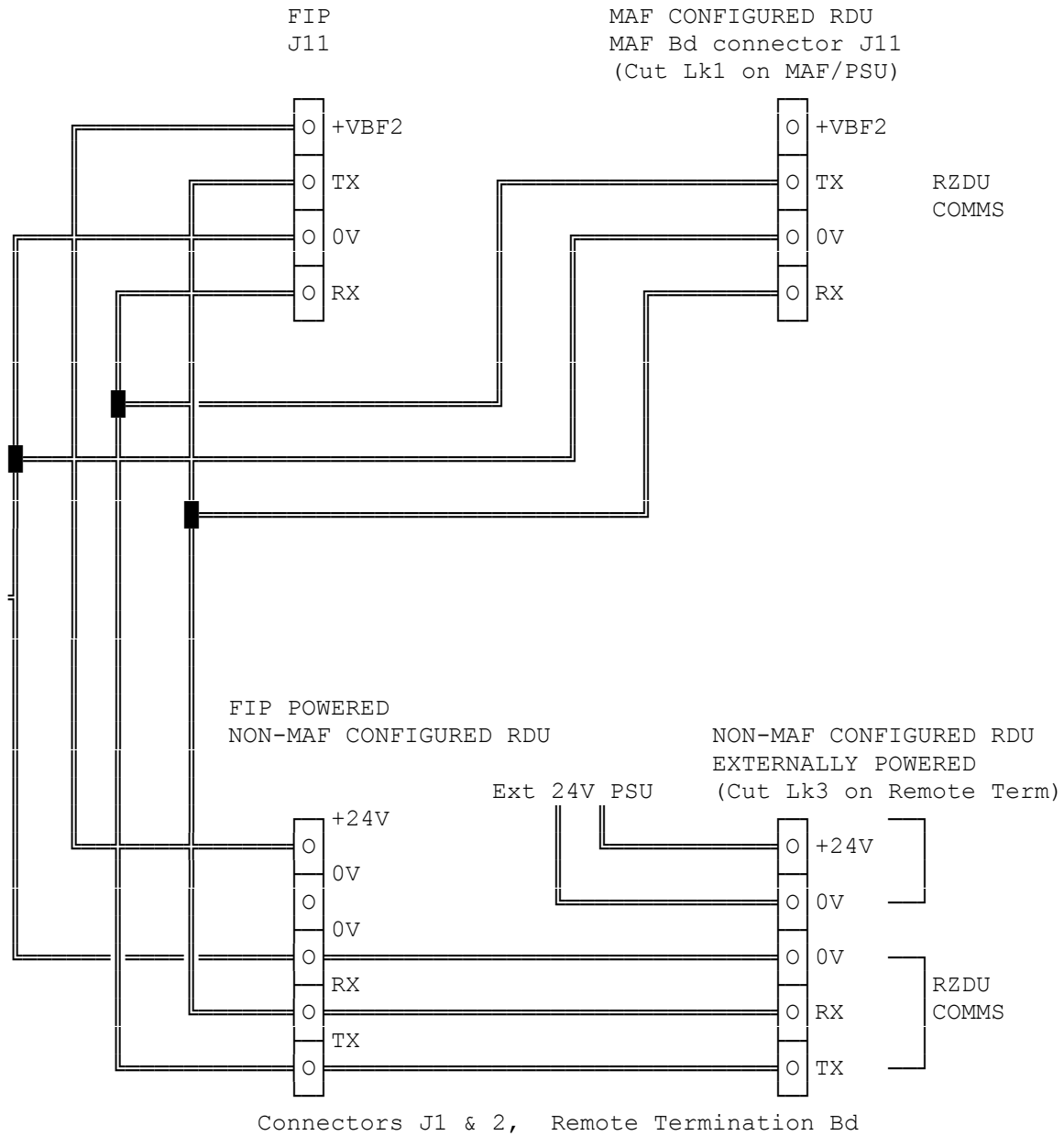

FIG 5.8.1
EXAMPLE OF RDU COMS WIRING

5.10 NDU INSTALLATION AND WIRING

5.10.1 INSTALLATION OF 19" NDU

The NDU is available as a 19" rack mount kit (FP0794). This must be installed as follows to meet the EMC requirements.

Using the RS485 board as a template, drill 4 x Ø3.5mm holes and deburr. Scrape away any paint on the inside face and mount the metal standoffs using 4 M3 x 6 screws and shakeproof washers. Mount the RS485 board onto the standoffs using M3 x 6 screws and M3 crinkle washers. Mount the 4U inner door onto the 19" rack and earth to the cabinet using the earth lead supplied.

Run the 10 way FRC from J7 (Network 1) on the Controller to J1 on the RS485 board, keeping it tight against the cabinet metalwork by using FRC clamps. Run +24V to the J5 terminals on the Controller, and the network cables to J3 on the RS485 board. Connect any screen on the network cables to the 0V ISO terminal on the RS485 board.

5.10.2 MCP CONNECTION

An NDU with a MAF/PSU board has an MCP connected to pins 3 and 4 of J6 on the MAF/PSU board as standard.

A slimline NDU has the facility for connection of an MCP, but the MCP has to be mounted on the wall, immediately adjacent to the NDU. Connection is made to pins 3 & 4 of J5, the 4 way "Spare Input Connector" on the NDU Controller/Display Bd. The wiring to the MCP is detailed in Fig 5.10.1

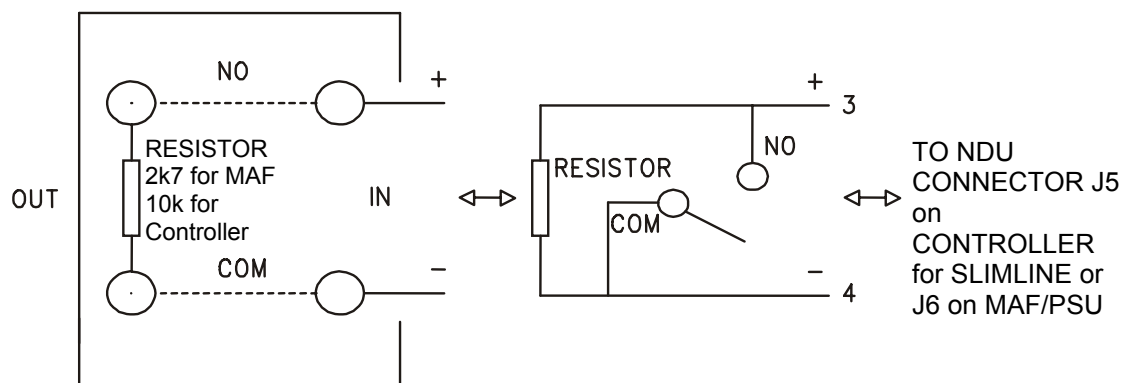

FIG 5.10.1
MCP CONNECTION FOR NDU, AUSTRALIAN MODE

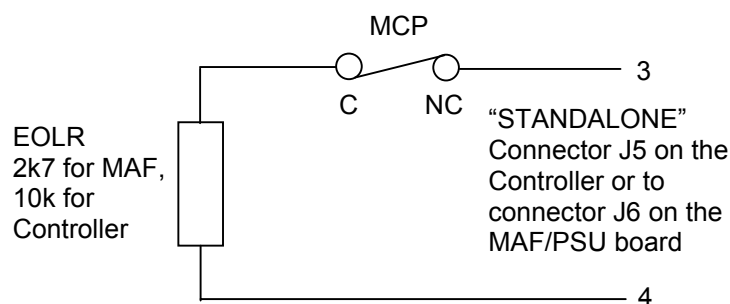

FIG 5.10.2
MCP CONNECTION FOR NDU, NEW ZEALAND MODE

5.11 NZ MODE INPUTS AND OUTPUTS

5.11.1 GENERAL

New Zealand mode operation may be enabled on an NDU but not on an F3200 fire panel.

An NDU with New Zealand mode enabled may be connected to a Panel-link network of panels which also have "New Zealand" mode enabled. The NDU may be used with or without a MAF board, and optionally with a NZ Display Extender board.

If a MAF board is used, the NDU may be used as the main brigade connection point of the network. The MAF board has relays for signalling alarm (normally energised), fault (normally de-energised) and standby (normally energised and normally wire-ORed with fault). The MAF board also provides a supervised BELL relay, two supervised ancillary relays, and an "isolate" relay; all of which can be controlled by output logic if desired.

5.11.2 NZ DISPLAY EXTENDER BOARD

The NZ Display Extender board, if fitted, is positioned at the end of the LED Display Board chain (the last LED Display board should have Lk1 removed), or connected directly to the controller J13 via an FRC (LM0092) if there are no LED Display Boards.

The New Zealand Display Extender board has the following inputs and outputs, accessible on the PA0483 Termination board, as shown in Fig 5.11.1.

Inputs (all active low)

- Trial Evac/Sprinkler operated (separate terminals, but internally connected)
- Silence alarms
- External defect
- Lamp test
- Building services restore
- Brigade test/brigade isolate (shared)
- Evac defect

Outputs

- Fire LED
- Defect LED
- Normal LED
- Ancil defect
- Ancil fire
- Lamp

Evac Defect/External Defect

The Defect and External Defect inputs may be programmed as to whether a defect is signalled for them or not. If defect is not signalled then they can be used as general purpose inputs accessible in output logic.

Building Services Restore

When the Building Services Restore input is activated, the BSR logic token is set true and this can be used in output logic to turn outputs off or on if necessary.

DISPLAY EXTENDER BOARD (CONTINUED)Trial Evac

When the Trial Evac input is activated, the Bell relay is energised and the BEL logic token is set true regardless of any silence alarms or bells isolate condition.

Silence Alarms

When the silence alarms input is activated, the Bell relay is de-energised and the BEL logic token is set false unless trial evac is asserted.

Brigade Test/Brigade Isolate

These conditions share the same input and when true, result in an “abnormal” system state (but defect is not signalled) that can be recalled with a system fault recall.

Lamp Test

This input can be used to test all the LEDs including the front panel LEDs, the LEDs on the New Zealand Display Extender board, the index lamp and any 16 zone LED display boards.

I/O 01	SPARE-	0V	SPKLR OP-	I/O 16
I/O 02	ANC DEF-		TRIAL EVAC-	I/O 15
I/O 03	ANC FIRE-	PA0483	SIL ALMS-	I/O 14
I/O 04	FIRE-		EXT DEF-	I/O 13
I/O 05	DEFECT-		LAMP TEST-	I/O 12
I/O 06	NORMAL-		BRIG ISOL/TEST-	I/O 11
I/O 07	LAMP-	+V	BSR-	I/O 10
I/O 08	LAMP+		EVAC DEF-	I/O 09

FIG 5.11.1
NEW ZEALAND EXTENDER TERMINATION BOARD

5.12 INSTALLATION : NZ DISPLAY EXTENDER BOARD & BRIGADE DISPLAYS

5.12.1 GENERAL

An NDU is not normally used as a brigade connection point. If an NDU is used as a brigade connection point then, in general, a separate display panel must be provided if there needs to be zone alarm indication to the attending Fire Brigade staff. The common MAF status display is provided by mounting an NZ Display Extender Board (PA0499) in the NDU cabinet and wiring to a display in a separate cabinet in one of the ways shown in Fig 5.12.1 and 5.12.2.

Sixteen-zone display boards are not normally connected to an NDU, but the two diagrams show how they can be connected if necessary. An NDU allows a maximum of four 16-zone display boards and each individual LED (48 LEDs per board) must be controlled using output logic which is generally too cumbersome for normal use.

The second cabinet is necessary because the LEDs mounted inside the NDU cabinet do not meet the requirements of NZ4512 with regard to visibility and viewing access. An NLDU (Network LED Display Unit), can often be used to more conveniently drive 16-zone display boards and show individual zone information as part of the brigade mimic display.

Any Ancillary Control Zone indicators on this external display must be coloured differently or be segregated from the zone alarm and common indicators, and be clearly labelled.

There are several methods for providing a separate display panel. Two approaches are detailed below.

NOTE 1: The information provided here is very similar to the information in the RDU installation manual LT0148 which may be useful to refer to.

NOTE 2: As stated above, 16 zone display boards are not normally connected to an NDU, nevertheless, the following sections describe how to do it if necessary. If an NLDU is used to drive 16 zone display boards, then the NLDU user manual LT0188 must also be referred to.

5.12.2 MIMIC DISPLAY

A mimic display uses the mimic outputs from the NDU's internal 16 Zone LED Indicator Boards to drive alarm LEDs in an external display. Each group of 16 zone alarms and the common indicators are extended in a separate 26 way FRC to the external display.

The number of FRCs between the NDU and the external display limit the practical separation distance. Since the cabling is not supervised in any way, the Fire Service or approving authority may place restrictions on this distance. The cable must be well protected mechanically by conduit, trunking or equivalent.

These parts are available for constructing displays of this type:

FP0475	FP, 16 ZONE LED DISPLAY EXTENDER KIT (C/W LOOM)
FZ3031	16 ZONE LED DISPLAY EXTENDER KIT, RHS POSITION
LM0044	LOOM, DISPLAY EXTENDER FRC, 2M, 26 WAY
LM0045	LOOM, DISPLAY EXTENDER FRC, 5M, 26 WAY (Longer and 3-way looms can be made to special order)

MIMIC DISPLAY (CONTINUED)

LM0092	LOOM, CONTROLLER TO FIRST DISPLAY, 1.2m
PA0483	PCB ASSY, IOR UNPROTECTED TERMINATION BOARD
PA0499	PCB ASSY, NZ DISPLAY EXTENDER BOARD
PA0769	PCB ASSY, 16 O/P MIMIC TERMINATION BOARD, C/W RESISTORS (As for PA0483 but 3k3 resistor per output)
PA0753	PCB ASSY, PICTURE FRAME DISPLAY, 16 LED MIMIC, 24V

Specially designed cabinets for Mimic Displays are no longer available.

Various FP1600 empty cabinets and the PA0787 FP1600 Mimic Display Board provide an alternative format.

At the display panel there are two possibilities:

- (i) Geographic Plan Mimic - the FRCs from the NDU are connected to Termination boards (PA0483). Individual LEDs with series resistors are mounted on the display panel and wired to these Termination boards. Figure 5.12.1 shows this arrangement. Alternatively, the PA0769 Termination Board has 3k3 resistors already fitted (gives 7mA LED current which is adequate for interior use).
- (ii) Column Format - where arrangement of zone alarms into columns is acceptable, LED Mimic Display boards can be used. This simplifies the wiring considerably. Figure 5.12.2 shows this arrangement.

Note that a special 3-way FRC is required for the Display Extender board, so that the miscellaneous inputs are accessible in the NDU cabinet. This is not a standard part, and will need to be made up to suit the application.

5.12.3 DISPLAY EXTENDER BOARD MISCELLANEOUS TERMINATION

The miscellaneous signals available through a NZ Display Extender Board are accessible via a 26 way FRC and PA0483 unprotected termination board. A termination pin out diagram is given in Fig 5.12.3. Refer to section 3 for electrical specifications of these signals, and to section 5.11 for their logical functions.

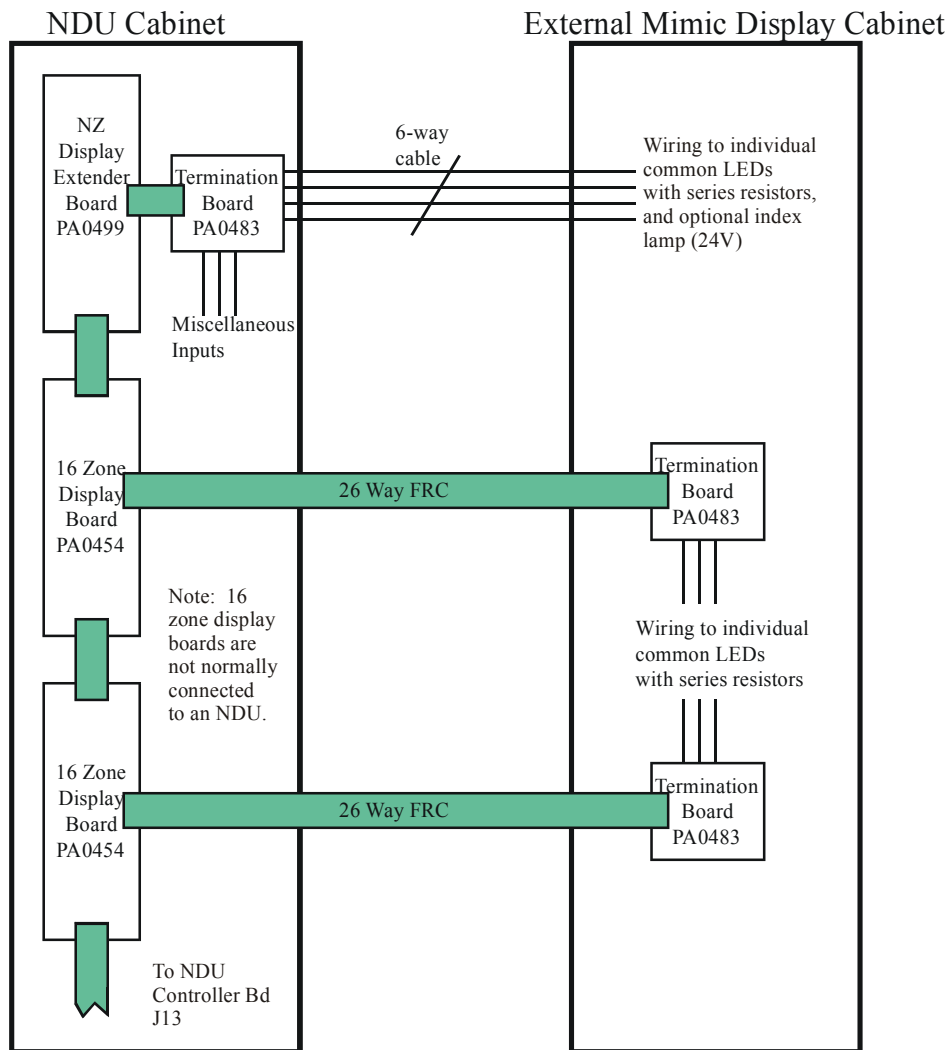

Note: PA0769 Termination Board can be used instead of PA0483
 PA0769 has resistors for LEDs already fitted to the PCB.

All shaded cables 26 way FRC.
 The first cable from the NDU Controller must be LM0092 (FZ3031 kit)

FIG 5.12.1
REMOTE PLAN MIMIC DISPLAY

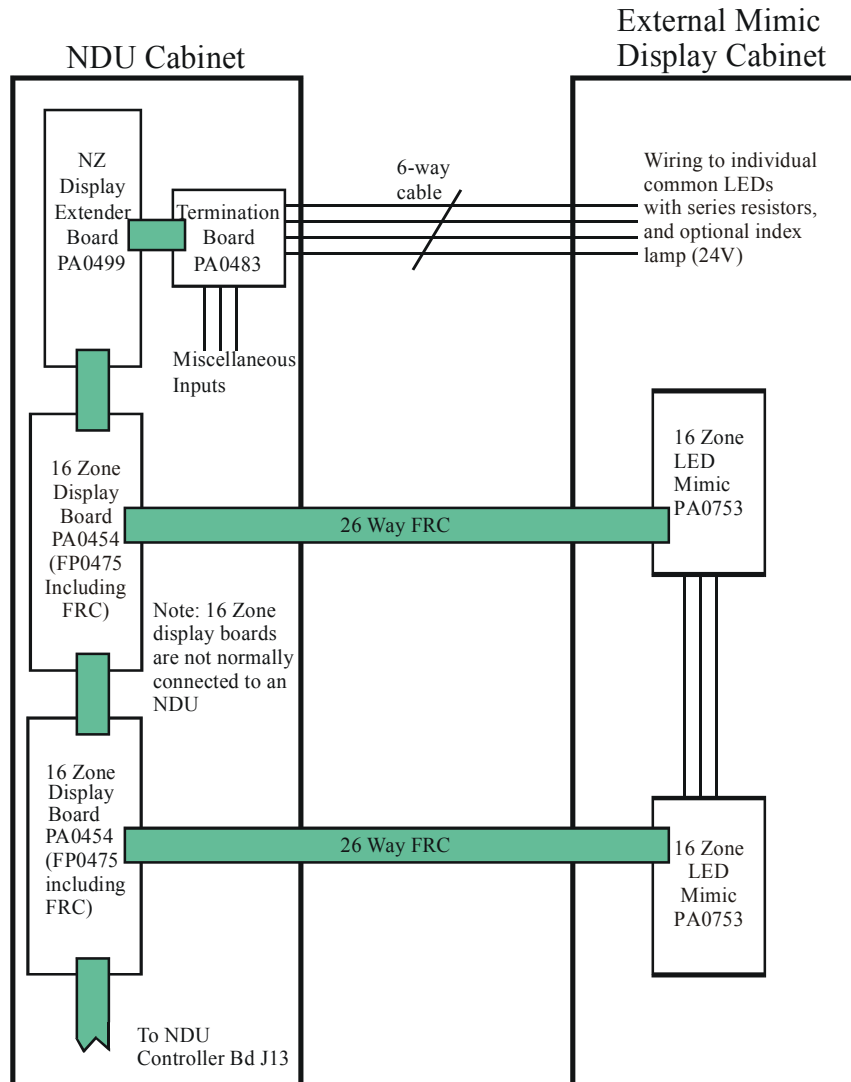

All shaded cables 26 way FRC.
The First cable from the NDU controller must be LM0092 (FZ3031 kit).

FIG 5.12.2
REMOTE MIMIC USING LED MIMIC BOARDS

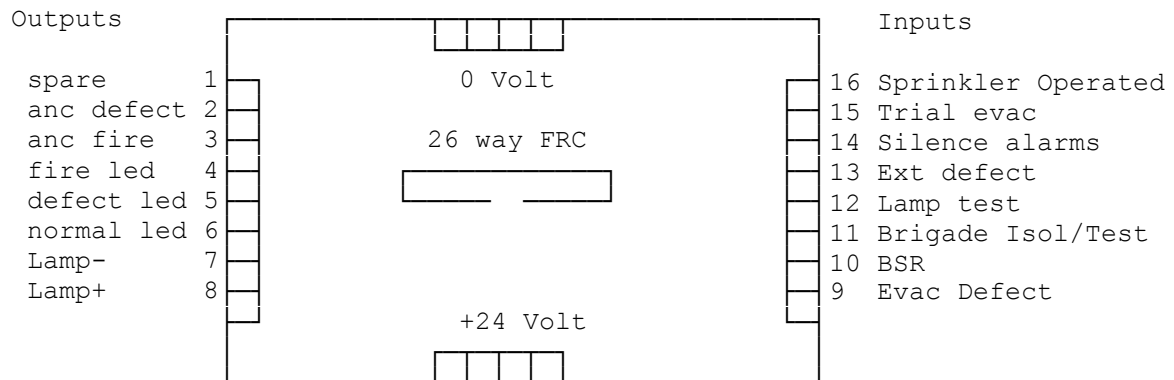

FIG 5.12.3
Terminations from NZ mode Display Extender Board on
unprotected termination board (PA0483).

NOTE:

Sprinkler Operated and Trial Evac share the same input and are electrically connected on the Display Extender Board. On an F4000/MX4428, Input 10 is used as Brigade Test, and Services Restore (BSR) is not provided.

CHAPTER 6 APPLICATIONS

6.1 AS1668 AIR CONDITIONING CONTROL

6.1.1 GENERAL

The following features of F3200 allow it to be easily adapted to make a Fire Fan Control and Indication Panel (FFCP) (referred to as AS1668 which is the relevant Australian and NZ Standard):

- 19" Rack mounting cabinet with standard light grey blank panels available, including 9½U (plastic), 7U metal (hinged), 4U metal, 3U metal;
- Standard modules available which include a PCB module (3 options) with switch and LEDs, a connector block for field wiring, and labels (see Fig 6.1.1).
- Programmable open collector output for driving LEDs (can enter logic equations for RUN, FAULT, STOPPED);
- Programmable relays for fan controls;
- Programmable time delays on duct sampling AZCs, with RAD and SAD options;
- Programmable AZCs for control inputs with two useable alarm states plus normal (plus faults) per AZC (i.e. logic equations can differentiate "manual" alarm (instant) from "detector" alarm (alarm));
- Programmable zones, allows non-latching, non-MAF (non-FF), non-Bells/Ancillaries, status only (i.e. Fan Control Panel output relays can switch AZCs and the corresponding zones can be programmed as "non-fire" zones with optional levels of "transparency" within the Fire Alarm System e.g. Faults, Alarms can be included/not included in the "totals" display and the "recalls").

The standard AS1668 PCB modules are held to the front panel (rear) by a nut on the threaded shaft of the rotary switch which is attached to the PCB. The LEDs mount in black plastic bushes and are soldered to the PCB (chrome bezel LEDs are available and can also be accommodated by the PCB). The adhesive label is black on clear, and the standard panels are light grey.

The standard colours for RUN, FAULT and STOP (stopped) are red, yellow and green, respectively.

Kits KT0111-113 comes complete with an assembly instruction (LT0159) which includes the circuit diagrams 1945-1-1 to 1945-1-4 also included in this section.

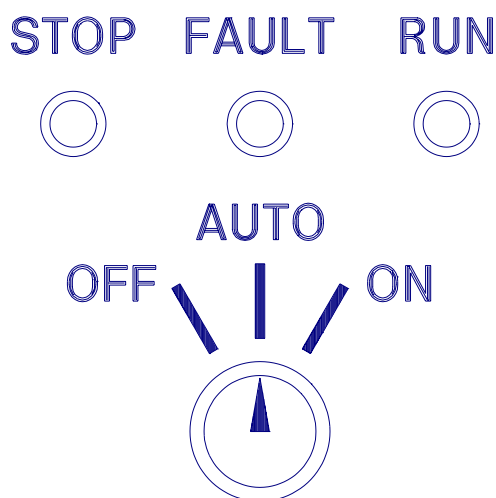

FIG 6.1.1
STANDARD AS1668 MODULE PANEL LAYOUT

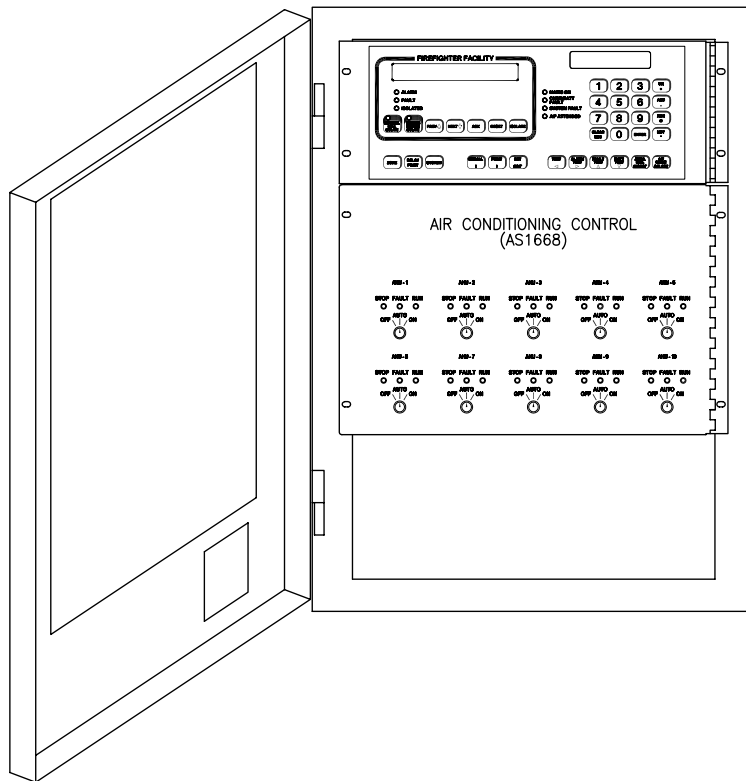

FIG 6.1.2
F3200 WITH TYPICAL AS1668 PANEL (10 UNITS)

6.1.2 CIRCUITS & ZONES

FIP End Inputs

The "off", "auto" and "on" inputs from the AS1668 Control Module can be connected to 0, 1 or 2 AZCs as desired.

One AZC per fan control is cheaper, but does not allow the LCD zone text to display "fan off" and "fan on", though the fan name can be put in the zone text, and for options A and C following, the word "off" could be programmed as zone text so that "Manual" Alarm is "on" and "off" Alarm is "off".

For option B, the text LCD would display "fault" for "off". Zone text would normally only be viewed by a zone status recall as AS1668 control inputs will (generally) be programmed as "status" zones (i.e. non-FFCIF).

Figs 6.1.3 and 6.1.4 show both options. Option 1 requires a Zener diode or a resistor (e.g. 560E) to give B2 voltage.

Note that the option shown in Fig 6.1.3 B ("off" <-> "fault") corresponds to the standard AS1668 Module circuits 2, 3 & 4 (see drawings 1945-1-1/4 following) and so is the "preferred" option for configuring with standard hardware.

CIRCUITS & ZONES (CONTINUED)

The option in Fig 6.1.3 A could be implemented by "tacking" the 560E resistor (or 6V8 Zener) onto the PCB. The 2 AZC option (Fig 6.1.4) could also be implemented by soldering the extra resistor and wires onto the unused contact of the rotary switch on the PCB.

In all cases, "auto" is zone "normal".

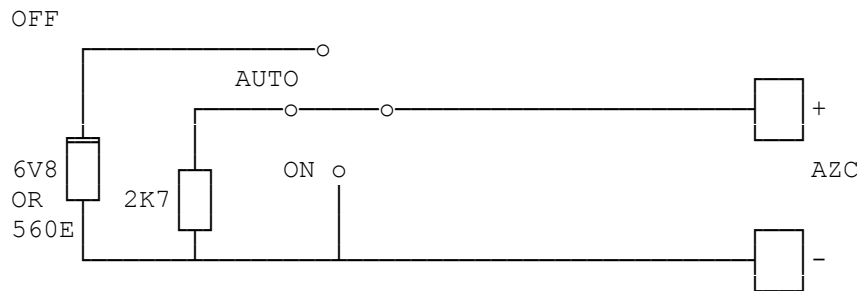

A. WITH A ROTARY SWITCH, "ON" IS B1 (INSTANT), "OFF" IS B2 (ALARM).

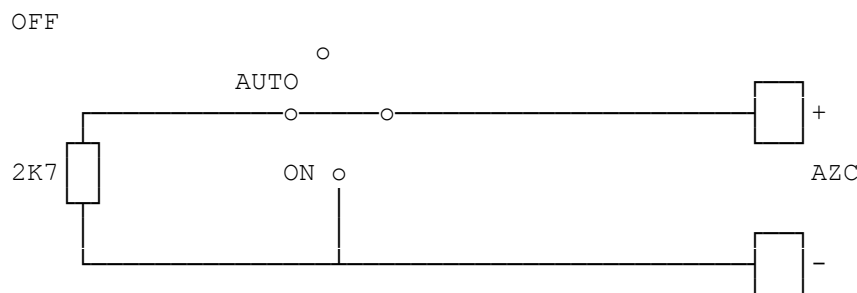

B. WITH A ROTARY SWITCH, "ON" IS B1 (INSTANT), "OFF" IS FAULT.

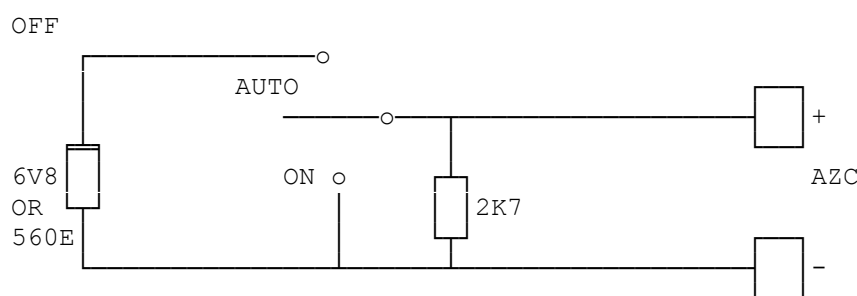

C. WITH A CENTRE-OFF TOGGLE SWITCH, "ON" IS B1 (INSTANT), "OFF" IS B2 (ALARM).

FIG 6.1.3
FAN CONTROL SWITCH WIRING WITH SINGLE AZC

CIRCUITS & ZONES (CONTINUED)

For **options A and C** in Fig 6.1.3, configure circuit Alarm Text as "manual" and voltage band B1 as "Instant Alarm" (refer to table below).

<u>Voltage Band</u>	<u>Default State</u>	<u>Program State</u>	<u>Fan Control</u>
B5	Fault		Switch wiring open circuit
B4	Normal		"Auto"
B3		Normal	"Auto"
B2	Alarm		"Off"
B1		Inst Alarm	"On"

Configure the zone as non-Latch, Status, non-Anc1/Warning System/External Bell.

In output logic, "off" is ZnD, "On" is ZnM, (for AZC number n).

For **Option B** in Fig 6.1.3, configuration is similar but in the output logic, "off" is ZnF and "on" is ZnA.

For two AZC inputs:

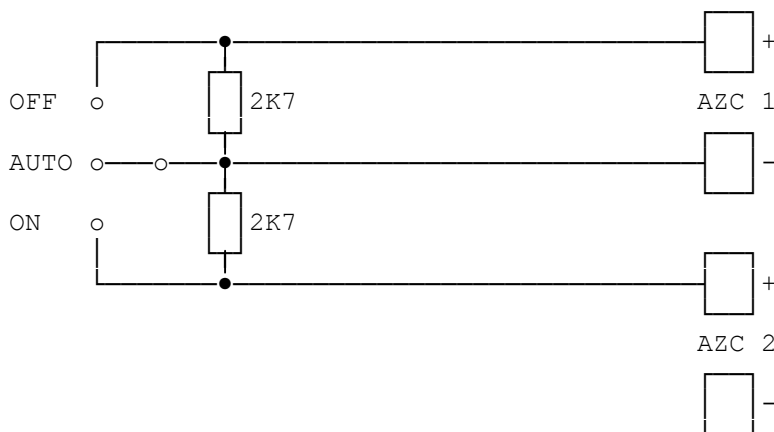

FIG 6.1.4
FAN CONTROL WITH TWO AZCs & ROTARY (OR CENTRE-OFF) SWITCH

Program B1 for both AZCs as "Instant Alarm", Alarm Text as "Manual".

Zone 1	Alarm	"Fan Control Off"
Zone 2	Alarm	"Fan Control On"
Both	Normal	"Fan Control Auto"

Configure both zones as non-Latch, Status, non-Anc1/Warning System/External Bell.

Fan Inputs

The exact requirement depends on the particular fan motor controller, and the contacts available (e.g. "Run", "Fault"). Commonly "Run" is provided by an air flow switch (AFS), and is required to connect to an AZC so that it can become part of a logic equation (as per circuits 3 & 4 of standard module 1945-1-1/4 following).

CIRCUITS & ZONES (CONTINUED)

Where a "Fault" contact is available, along with "Run", both can be put onto a single AZC with the NO "Fault" contact shorting the AZC and voltage band B1 programmed as "Fault" (refer to Fig 6.1.5 A). Alternatively, the NC "Fault" contact can be put in series for open circuit Fault, and the NO "Run" contact can short the AZC, with B1 programmed as "Alarm" (ZnD). (Refer to Fig 6.1.5 B). Note that in A, Fault overrides Run, and in B, Run overrides Fault. The priority in B can be reversed, but not in A.

The zone should be configured as non-latching.

If a "run" contact is used to short a Zener across the AZC (i.e. run is B2 = Alarm) and the normal state of the fan is "run", then the zone mapping to MAF should be configured as "Status Only" so that the fan "Run" state is not shown in the "Totals" or "Alarm Recalls".

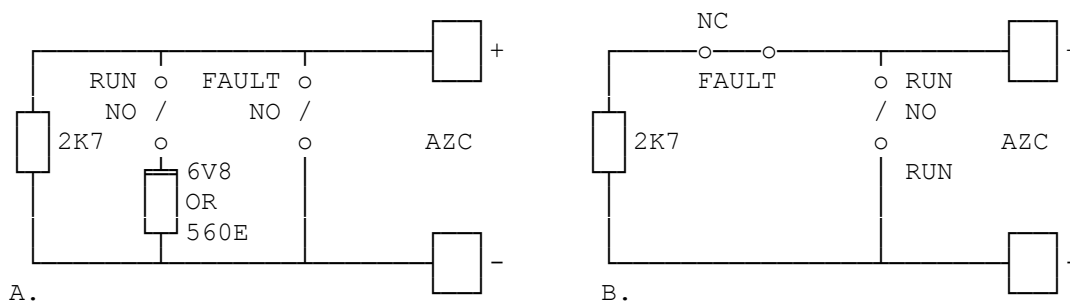

FIG 6.1.5
EXAMPLE OF FAN RUN & FAULT WIRING TO AZC

6.1.3 RELAYS

The exact number of relays per fan control and the logic required depends on the particular building and air conditioning plant.

Typically, one relay is required per fan to switch an interposing relay in the fan control equipment, with a possible logic equation as follows:

$R5 = Z15D + Z15N.Z5A$ i.e. ("off") or ("auto" and duct alarm)
(ie. the relay turns on to turn the fan off).

Where: Relay 5 is the Fan Control relay for a normally running fan
Zone 5 is the associated Air Duct Smoke circuit

Zone 15 is the associated Fan Control switch circuit with ...
Z15D (band B2) = "Fan Off"
Z15M (band B1) = "Fan On"
Z15N (bands B3, B4) = "Auto"

Note that the zone range facility is useful in programming controls where selective, automatic switching is required. E.g. if zones 1-10 correspond to ducts in levels 1-10 of a building, and the logic requires Relay 5 to operate if Zone 5 is in alarm but zones 1-4 and 6-10 are not, the equation for R5 above would become:

$R5 = Z15D + Z15N.Z5A.^ (Z1:4(1)A+Z6:10(1)A)$

Note also, that if the interposing relay (fan control input) is 24V at less than 100mA then an open collector (O/C) may be used as per circuit 1 of 1945-1-1/4 following.

6.1.4 LEADS

The 3 LEDs may be: switched directly as per circuits 1 and 2 of 1945-1; driven off 3 open collector (O/C) outputs or driven off 2 O/Cs with a Zener diode as shown in Fig 9.1.6 and 1945-1-3. Note that where the FIP has a number of detector circuits, the open collector outputs associated with these AZCs may be used for driving the AS1668 LEDs and so it doesn't matter if the AS1668 panel requires more open collectors than circuits.

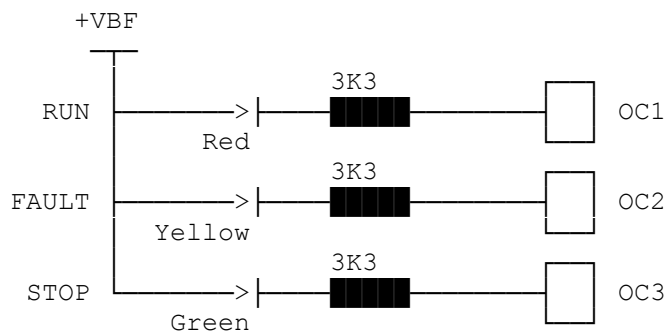

A. THREE OPEN COLLECTOR O/PS PER FAN (Ref 1945-1-4).

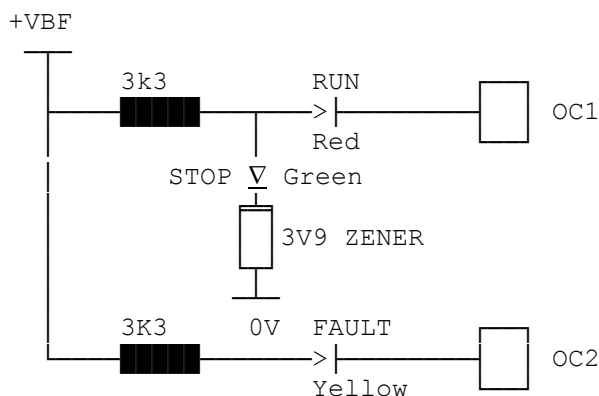

B. TWO OPEN COLLECTOR O/PS PER FAN (Ref 1945-1-3).

For other LEDs (e.g. Chrome Bezel LEDs) a lower value (higher current) resistor may be required.

FIG 6.1.6
WIRING OF FAN CONTROL LEADS

Note that the logic required for the LEDs in Option B is as follows:

LEDs			OUTPUTS	
RUN	FAULT	STOPPED	OC1	OC2
off	off	on	off	off
on	x	off	on	x
x	on	x	x	on

Where x = off or on (don't care).

6.1.5 AS1668 CONTROL MODULE & DRAWINGS

The following drawings are of 4 typical configurations using the AS1688 Control Module, 1945-1.

Circuit 1 uses Module Type 1 (KT0111)

Circuit 2 uses Module Type 2 (KT0112)

Circuits 3 and 4 both use Module Type 3 (KT0113), with selective "snipping" out of components as required.

1945-1-1, AS1668 CONTROL MODULE, CIRCUIT 1

1945-1-2, AS1668 CONTROL MODULE, CIRCUIT 2

1945-1-3, AS1668 CONTROL MODULE, CIRCUIT 3

1945-1-4, AS1668 CONTROL MODULE, CIRCUIT 4

6.2 GASEOUS FIRE EXTINGUISHING

6.2.1 GENERAL

The following features of the F3200 make it well suited to gaseous fire extinguishing applications as required by AS4214:2002.

- AZC Alarm Text for "pressure switch", "manual", can be used for the various inputs;
- Zones can be programmed as latch/non-latch, MAF/non-MAF as required, e.g. non-latch, non-MAF, for "Gas Inhibit" input;
- Zone range operand allows easy programming of "voting systems" on detector circuits e.g. 2 out of 3;
- Open collector O/Ps can be programmed to drive LEDs such as "Gas Initiated", "Gas Inhibited", etc;
- Programmable timers included as standard (0-250 sec);
- Programmable relays, with supervision option;
- Operation not fixed by hardware, as virtually any required logic equation for outputs (using AND, OR, NOT, XOR) can be entered;
- Fuse protected battery-backed supplies available via 2A fuse and 6A fuse;
- Standard hinged, screened 7U Gas control doors available complete with LEDs, switches and looms for 1, 2, 3, 4 Gas Zones (Part Number ME0438 to ME0441 respectively);
- Standard non-hinged, screened 1U Panel as per above for 1 Gas Zone (Part Number ME0442);
- Standard Local Control Stations (LCSs) and AVI warning signs available. (LCS includes "Gas Start", "Gas Inhibit" switches, status LEDs). AVIs include selectable Alert and Evac tones and can be ordered with lettering such as FIRE ALARM / DO NOT ENTER, etc.

Two standard F3200 panels are available factory-fitted and programmed for gaseous fire extinguishing applications.

FP0876 FP,F3200 AS4428 FIP,8U CAB,3A,1U GAS CTRL,PRE PROG

FP0877 FP,F3200 AS4428 FIP,STD CAB,6A,1U GAS CTL,PRE PROG

FP0876 is an F3200 assembled into the 8U cabinet (FP0784). It comes complete with the ME0442 1 zone 1U gas control module and an 8 Relay Module. It has a 3A power supply.

FP0877 is based on a 6A (PSU) F3200 assembled in the standard 15U cabinet (FP0782). It comes complete with an ME0442 1 zone 1U gas control module pre-wired to the 8 Zone Module and an 8 Relay Module.

The gas control doors (ME0438-ME0442) are wired to provide 2-wire connections to the AVI Mk2s. Drawings 1931-123 and 1931-124 show how these are wired to F3200 and the external devices: AVI MK2, LCS, etc.

Special factory-assembled panels can be made to order to meet the specific requirements of jobs.

6.2.2 LOGIC & CONFIGURATION

A commonly used logic diagram for a dual circuit (single gas zone) gaseous fire extinguishing system is shown in Fig 6.2.1. This can be used with an F3200, ME0438-ME0442 gas control door, one or more Local Control Stations (FP0570), and multiple AVI Mk2. The configuration and programming of F3200 is as follows.

LOGIC & CONFIGURATION (CONTINUED)

The logic equations for F3200 to match Fig 6.2.1 are as follows.

where: OC1 = Gas Initiated LED (i.e. Timer Running)
 OC2 = Manual Release Activated LED (i.e. LCS Gas Start)
 OC3 = Gas Discharged LED
 OC4 = System Inoperative (i.e. any isolate or fault in Gas Control System)
 OC5 = Gas Inhibited LED

Zone 1 = Detector Cct 1
 Zone 2 = Detector Cct 2
 Zone 3 = Gas Start (LCS)
 Zone 4 = Gas Released (Pressure Switch)
 Zone 5 = Gas Inhibit (LCS)
 Zone 6 = Gas Isolated (i.e. Gas Discharge Isolate switch operated, see note 3)
 Zone 7 = Lock-off Valve (if required, see note 9)

Relay 1 = Alert or Evac O/P (1st stage sign FIRE ALARM)
 Relay 2 = Evac O/P (2nd stage sign EVACUATE and DO NOT ENTER)
 Relay 3 = Gas Release Solenoid
 Relay 4 = System Inoperative sign
 Isolate = Guard Relay (see note 2)

Timer

T1 [S30:0] = V1 30 Second time delay from "Gas Initiated" (second stage).

Variables

V1 = Z1A . Z2A . ^Z5A + Z3A

Open Collector LEDs

OC1 = V1
 OC2 = Z3A
 OC3 = Z4A
 OC4 = Z5A + Z6A + OC5 + Z7A + Z3:7(1)I + Z1:7(1)F + R1F + R2F + R3F + R4F + R1I + R2I + R3I + R4I + Guard I (see notes 2,9)
 OC5 = Z1:2(1)I

Relays

R1 = Z1A + Z2A + Z3A + Z4A (Alert or Evac : Stage 1 or Stage 2)
 R2 = Z4A + V1 (Evac Stage 2)
 R3 = T1 (Gas Release)
 R4 = OC4 (System Inoperative)
 ISO (or Rn) = V1 (Guard) (see note 2)

Configure Circuits

AZC	Alarm Text	B1
Circuit 1	Smoke (1)	-
Circuit 2	Smoke (1)	-
Gas Start	MCP/Manual (4)	-
Gas Released	FSW (3) or PSW (6)	Alarm (2)
Gas Inhibit	MCP/Manual (4)	-
Gas Isolated	MCP/Manual (4)	If required (see note 3)
Lock-off Valve	VMD/Valve (5)	If required (see note 9)

(Circuits 1 and 2 use all default settings).

LOGIC & CONFIGURATION (CONTINUED)

Configure Zones

Zone	Latch	MAF	Anc1	Anc2	Bells
Circuit 1	-	-	-	-	-
Circuit 2	-	-	-	-	-
Gas Start	Y	-	-	-	- (see note 10)
Gas Released	-	-	-	-	-
Gas Inhibit	N	N	N	N	N
Gas Isolated	N	N	N	N	N If required (see note 3)
Lock-off Value	N	N	N	N	N If required (see note 9)

(Zones 1-4 use all default settings. Zone 3 may be required to be non-latching. See note 10.)

Configure Relay Supervision

Relay	Enable	Latch	MAF	LED	Isolate	Test	Sup.Act
1 Alert	Y	Y	Y	-	-	-	-
2 Evac	N	Y	Y	-	-	-	- (See Note 11)
3 Gas Release	Y	Y	Y	-	-	-	-
4 Sys Inoperative	Y	Y	Y	-	-	-	-

6.2.3 NOTES

- The variable V1 is used to initiate the timer rather than OC1 because outputs (including OC) can be tested from the keypad. It is not desirable to have a "test" function initiating the timer which releases gas.
- The Guard relay is used to reduce the chances of accidental Gas Release (e.g. by someone performing a "Test " on the Gas Release Relay). (The test function may be inhibited, as may Isolate.) It uses a normally open set of contacts and is inserted between +VBF2 and the NO terminal of the Gas Release relay (R3). It is preferable to use an unused Brigade Relay (rated at 5A dc resistive) e.g. Isolate, if available (not Standby), else an ancillary relay, or a module relay (each rated at 2Adc resistive) on a separate 8RM to Gas Release. For multiple zones, a Module Relay "Guard" relay can be common for 2 Gas zones, or Brigade Relay "Guard" relay can be common to up to 5 Gas zones for 1A actuator loads. The common Guard relay should be programmed to operate off the OR of the variables. For example:
ISO = V1 + V2 + V3 for a 3 Risk FIP which used ISO as the Guard relay.
If an Ancillary Module relay is used as the Guard relay, then +ARnI or +RnI should be added to the equation for OC4.
- The Gas Discharge Isolate switch turns on the Gas Isolated LEDs on the gas control doors and LCSs directly, and causes a Gas Release relay supervision fault. The third set of contacts on the Gas Discharge Isolate switch is connected to AZC 6 (Gas Isolated) as shown on Drawings 1931-123, 124 so that "Gas Isolated" status can show on the LCD, be logged, and repeat from the FIP to an RZDU or remote FIP via a network. A suitable EOLR has to be soldered across the switch contacts (yellow and black remit wires) at time of building.
- Snub (suppress) inductive loads (e.g. solenoids) with a suitably rated reverse diode.
- The Gas Discharge Isolate switch disconnects both wires to the solenoid. When not isolated, however, the -ve wire is connected to 0V and only the positive supply is switched by the relay. This allows the relay supervision to check for resistance from the relay "common" contact to 0V.

NOTES (CONTINUED)

7. See Section 6.2.4 re use of actuators.
8. Solenoids are typically less than 400 Ohms and require a diode (of sufficient rating) to be wired in series at the solenoid to allow supervision. If two solenoids are connected in parallel on one circuit the supervision will not detect one being disconnected. Where multiple release circuits are diode connected (+ve & -ve legs) onto a common solenoid, the supervision will detect shorts, but not all opens.
9. If a Lock-off valve is not required, then Z7 is not required and can be left out of the equations (standard programming of FP0876 and FP0877). Note that AS4214 requires the Lock-off Valve to isolate both poles of the Gas Release solenoid / actuator. This is not done within the standard wiring and therefore needs to be done externally with microswitches (or a relay).
10. The standard LCS Gas Start switch automatically turns on when the glass is broken. Some customers may require a different switch that can be turned off after the glass is broken, and hence cancel the timer and prevent gas release.
11. Enable supervision on Relay 2 if using a 3-wire connection to the Alert/Evacuate warning signs.

6.2.4 USE OF ACTUATORS

Where a CV-98 actuator is used it must be connected in series with the 427354 current regulator, fitted at the furthest point to act as the EOL.

A single actuator should be connected in reverse, i.e. with the black wire to the incoming +ve voltage, so that the supervision can detect that the element has been fired. See Figure 6.2.2(a).

Multiple actuators may be connected in series on one circuit, but each **must** have the red wire to the incoming +ve voltage. See Figure 6.2.2(b). Note the F3200 supervision cannot detect the difference between an unfired element (<2 Ohm) and a fired one. The actuator has 3 series forward diodes across the element so that current will continue to flow through it after the element has fired. With F3200 if both actuators fire, a supervision fault may or may not be generated.

Where series resistors have been used (in existing circuits) to limit the current, a series diode must be fitted as the EOL. It must be a silicon diode (not Schottky) rated at 2A_{dc} or higher, e.g. 1N5404. See Fig 6.2.2(c). The series resistor(s) must be located in the F3200 panel.

The maximum number of actuators connected in series in one circuit appears to be quoted by the manufacturer as 2. The following estimates for the Metron Protractor and 427354 current limiter (not confirmed by the manufacturer, consult the manufacturer) suggest that up to 4 actuators may be fitted to a circuit with a current regulator and up to 4 Ohms cable resistance.

Allow: 21V as worst case battery voltage; 6.5V drop for regulator; 2.5V drop per actuator; 1V per Ohm of cable resistance.

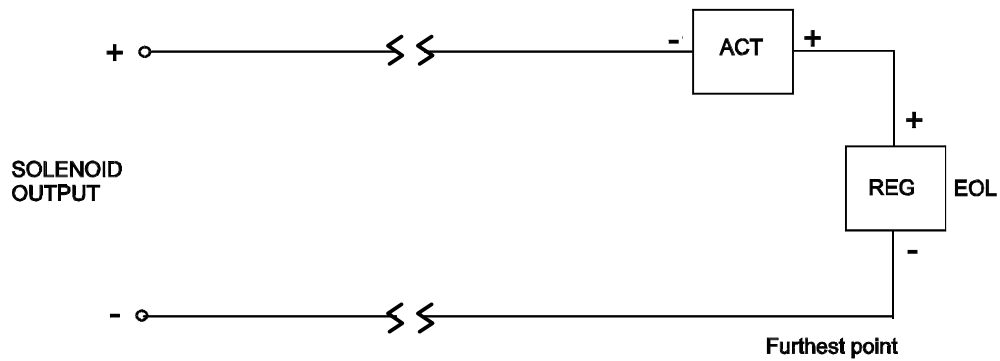

a) Single device with regulator at furthest point

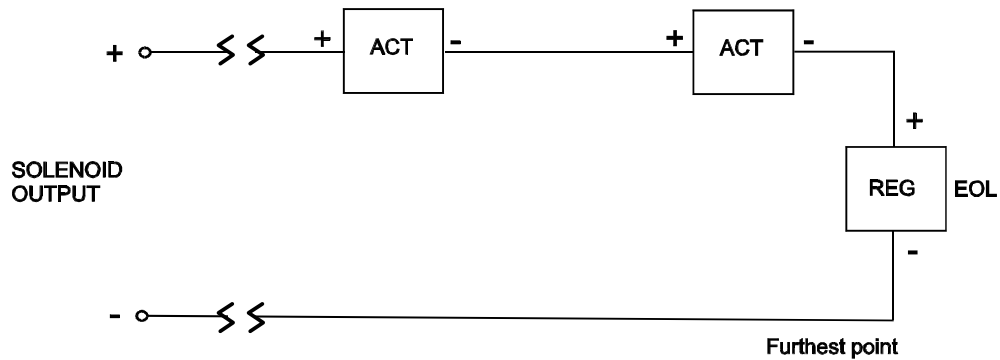

b) Multiple devices with current regulator at furthest point (EOL)

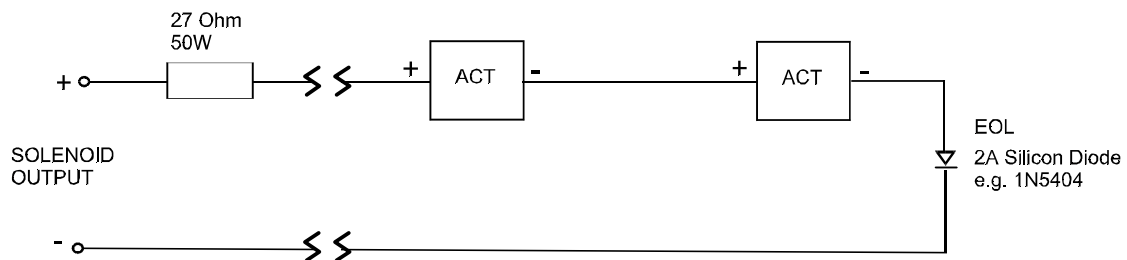

c) Multiple devices with limiting resistor (not recommended method).

FIGURE 6.2.2
CONNECTING CV98 ACTUATORS

6.2.5 AVI SIGNS

The AVI is an illuminated, 24Vdc warning sign with an internal sounder that produces AS2220 Alert and Evacuate warning tones or the ISO 8201 Evacuate signal (requires V1.20 or later software for ISO signal). It has two independent sets of indication (i.e. top and bottom), two signal inputs, and can be configured to provide the combinations of tone and illumination required for gas release warning signs. It can be ordered with one of a number of standard faceplates with wording such as FIRE ALARM / EVACUATE AREA.

Two models of AVI have been produced.

- The original AVI (FP0628) which uses incandescent lamps and produces only AS2220 tones;
- The AVI Mk2 (FP0853/4) which uses LEDs.

The wiring and set up for these AVIs are different.

6.2.5.1 AVI Mk2

Two standard versions of AVI Mk2 are available, with the faceplates (such as FIRE ALARM/DO NOT ENTER) ordered separately. FP0853 has two rows of red LEDs (i.e. to illuminate the top and bottom rows of lettering). FP0854 has 3 rows of yellow LEDs as required for the 3 line XXXX SYSTEM INOPERATIVE signs.

AVI Mk2s have 3 pairs of terminals that provide connection to the FIP, namely "COM", "IN-T" and "IN-B". Pairs are provided to allow "daisy chaining" of multiple AVIs off one FIP output circuit. A fourth pair "SYNC" allows for synchronisation of tone and LED flashing on daisy-chained AVIs.

IN-T operates the top LEDs, for which the default tone is Alert. IN-B operates the bottom LEDs for which the default tone is Evac. COM is the power supply common in a 3-wire arrangement and may be positive or negative. Negative is generally used as that is required for the FIP relay supervision.

With a 2-wire connection from the FIP to the first AVI (3-wires to further AVIs if synchronised) when IN-T is positive and IN-B is negative the top LEDs flash, when IN-B is positive and IN-T is negative the bottom LEDs flash.

With a 3-wire connection from the FIP to the first AVI (4 wires to further AVIs if synchronised), a common negative is used and a positive voltage applied to IN-T/IN-B activates the top/ bottom LEDs. Note the bottom indication/tone overrides if both In-T and In-B are applied.

The wiring diagram 1931-124 for the gas control doors ME0438-442 shows a 2-wire connection, but can be used for a 3-wire connection (see below). Both facilitate supervision of the AVIs by the FIP relays for which a 2k7 resistor is a suitable EOL. Refer to Figures 6.2.3 and 6.2.4.

The logic equations in 6.2.2 for RL1 and RL2 work for both 2-wire and 3-wire because Evac overrides Alert and the default setting for IN-B turns on the top LEDs with the bottom.

However for 3-wire connections RL2 must be re-wired and configured as supervised (program supervision as enabled and fit Lk2 to S on the 8 Relay Bd).

Note the System Inoperative sign requires only one relay to switch 24V to IN-B, with IN-T (or COM) wired to 0V. Refer to Figure 6.2.5. Refer to the appropriate AVI instructions to disable the Evacuate tone.

AVI Mk2 (Continued)

The configuration of some commonly used signs is as follows.

Function		Illuminate	Tone	Polarity +/-	Links Fitted
Top:	FIRE ALARM	Top	Alert	IN-T/IN-B	-
Bottom:	EVACUATE AREA	Both	Evac	IN-B/IN-T	-
Top:	FIRE ALARM	Top	Alert	IN-T/IN-B	-
Bottom:	DO NOT ENTER	Both	Evac	IN-B/IN-T	-
Top:	DO NOT ENTER	Top	Evac	IN-T/IN-B	3
Bottom:	XXXX GAS DISCHARGE	Both	Evac* ¹	IN-B/IN-T	3
Both:	XXXX SYSTEM INOPERATIVE	Both	None	IN-B/IN-T	1, 2

*1 The AVI Mk2 has a third tone (RH3), which could be generated on Gas Discharged. Refer to the particular AVI instructions for setting the links as the function of the links depends on the software version fitted.

Options for XXXX include: CO2; INERGEN; FM-200.

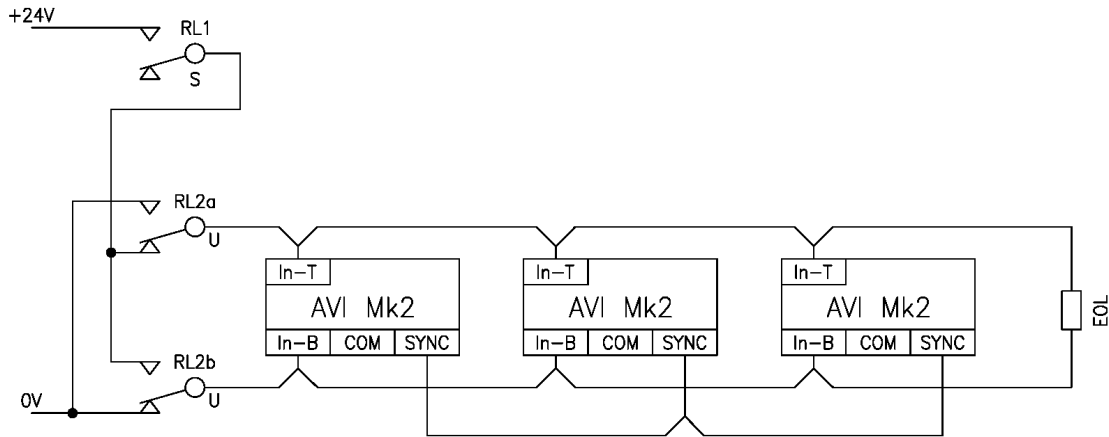

For FIRE ALARM / DO NOT ENTER, FIRE ALARM / EVACUATE AREA
 RL1 = Stage 1 OR Stage 2 S = Supervised U = Unsupervised
 RL2a = RL2b = Stage 2 RL2a, RL2b can be two separate relays driven together.
 LK1-LK6 not fitted. EOL = 2k7

For DO NOT ENTER / XXXX GAS DISCHARGED with the bottom lines having RH3 tone and operating off Gas Discharged.
 RL1 = Stage 2 OR Gas Discharged. S = Supervised U = Unsupervised
 RL2a = RL2b = Gas Discharged RL2a, RL2b can be two separate relays driven together.
 LK3, LK6 fitted.

FIGURE 6.2.3
AVI MK2 WIRING USING 2 WIRES

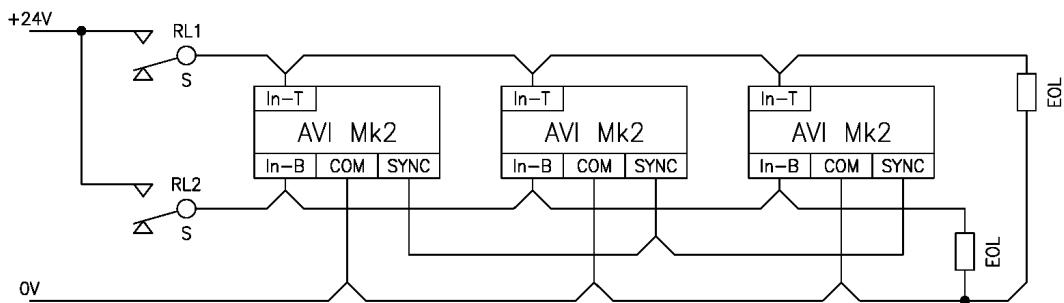

For FIRE ALARM / DO NOT ENTER, FIRE ALARM / EVACUATE AREA
 RL1 = Stage 1 S = Supervised EOL = 2k7
 RL2 = Stage 2 LK1-LK6 not fitted.

For DO NOT ENTER / XXXX GAS DISCHARGED with the bottom lines having RH3 tone and operating off Gas Discharged
 RL1 = Stage 2 LK3, LK6 fitted.
 RL2 = Gas Discharged S = Supervised

FIGURE 6.2.4
AVI MK2 WIRING USING 3 WIRES

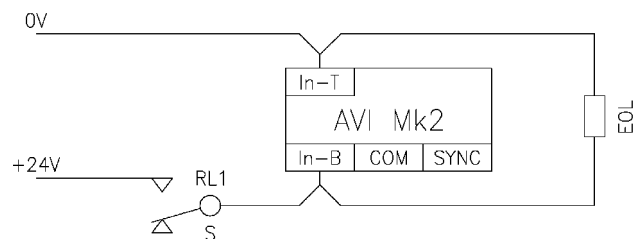

For XXXX SYSTEM INOPERATIVE
 RL1 = System Inoperative S = Supervised
 LK5 and LK6 fitted (tone disabled).
 Alternatively 0V could be connected to COM.
 Only one unit is typically required, but more could be added as per the diagrams above.

FIGURE 6.2.5
AVI MK2 SYSTEM INOPERATIVE

6.2.5.2 Original AVI

Original AVIs (FP0628) have three pairs of terminals that accept signals from the FIP, namely '+24V', 'ALERT-', and 'EVAC-'. They can be connected and operated in two modes, namely 2-wire and 3-wire.

The typical connection for 3-wire mode has the +VBF supply connected to +24V, with switched 0V signals to ALERT- and EVAC- respectively, as was used on the original gas control doors (ME0005 – ME0069 see drawing 1931-47).

In 2-wire mode, the +24V terminals are not used. For an EVAC input, the +ve supply is connected to ALERT- (i.e EVAC+) and the -ve supply (0V) is switched to EVAC-, and vice versa for Alert. Note the System Inoperative sign is configured for 3 wire special mode, but only two wires are required.

However these arrangements do not support supervision of the wiring to the AVIs. For supervised outputs the recommended method is to use only AVI MK2s and convert the ME0065 – ME0069 gas control door to a common 0V and switched 24V outputs – refer Section 6.2.6.

All signs should be configured for flashing illumination as that attracts attention and saves power. Note the original AVI has incandescent lamps that draw a large current.

The configuration of some commonly used signs is as follows.

Function	Illuminate	Tone	Note
1 Top: FIRE ALARM Bottom: EVACUATE AREA	Top Both	Alert Evac	
2 Top: FIRE ALARM Bottom: DO NOT ENTER	Top Both	Alert Evac	
3 Top: DO NOT ENTER Bottom: XXXX GAS DISCHARGE	Top Both	Evac Evac	a. a.
4 Both: XXXX SYSTEM INOPERATIVE	Both	None	

Function	Input	Lamps	Tone	Mode	DIL SW On	DIL Sw Off	Lk1,2	Lk3	Lk6	Notes
1	Alert- Both	Top Both	Alert Evac	3-wire std	1,3,5,6	2,4,7,8	1-2	1-2	On	
2	Alert- Both	Top Both	Alert Evac	3-wire std	1,3,5,6	2,4,7,8	1-2	1-2	On	
3	Evac-	Both	Evac	2-wire	2,3,5,6	1,4,7,8	2-3	1.2	Off	b.
4	Alert-	Both	None	3-wire spcl	1,3,5,6, 8	2,4,7	1-2	2-3	On	

Notes

- a. The option of top lamps with Evac tone for one input, and both lamps with Evac tone for the other, is not directly supported. But it can be arranged by mounting the AVI upside down.
- b. For this configuration the +ve supply is wired into Alert-, not +24V.

6.2.6 USING OLD ME0065 – ME0069 GAS CONTROL DOORS

Older F3200 gas panels were supplied with the ME0065-69 gas control doors (refer drawing 1931-47). These provide a common +24V supply and switched 0V outputs to activate the warning signs. They were designed for the original FP0628 AVI, but do support the Mk2 AVI. However, as wired these outputs are not suitable for supervising the wiring to the warning signs, as is now required.

These gas control doors can be modified to common 0V, switched 24V outputs to enable supervision of the warning signs. But in this case the original FP0628 AVIs cannot be used.

Two options exist for this – replace the gas control door with the equivalent 2-wire version (ME0438-ME0442), or modify it as shown in Drawing 1931-132 and in the steps as follows:

1. Turn power to the panel off and physically isolate the actuating device (operate the Gas Discharge Isolate switch). As a further precaution when working on gas extinguishing systems, disconnect the actuator or remove it from the gas release valve. Identify the thick black wire that runs from the Relay 1, 2 and 4 NO terminals to 0V on the MAF/PSU. Disconnect it from the MAF/PSU 0V terminal and connect to +VBF2 (or similar) instead. Place some red insulation tape around each end of the insulation to indicate it is now a positive wire, not negative.
2. Disconnect the two thick red wires that connect to the Sign+ screw terminal. Discard the one that runs to the +24V screw terminal, and reconnect the one that runs to the MAF/PSU to the +24V screw terminal.
3. Run a thick black wire from the Sign+ screw terminal to 0V on the MAF/PSU.
4. Re-label the following screw terminals:

Sign+	as	Sign-
Alert-	as	Alert+
Evac-	as	Evac+
SIO-	as	SIO+
5. Run 3 wires to the Alert/Evac (Stage 1/Stage 2) sign(s) and 2 wires to the SIO sign. Connect Sign- to COM, Alert+ to IN-T, Evac+ to In-B on the Alert/Evac signs. Connect Sign- to com (or In-T) and SIO+ to In-B on System Inoperative Sign (set the links to disable tones). Fit a 2k7 ELD from each of Alert+, Evac+, and SIO+, to Sign- (0V) at the last AVI.
6. Configure Relays 1, 2, 3, and 4 for supervision (fit Lk 1-4 to the S position) on the 8 Relay Board.

USING OLD ME0065 – ME0069 GAS CONTROL DOORS (CONTINUED)

7. Enable supervision on Relay 2 (Evacuate Relay) and use the following logic in the programming.

Relay 1 (Alert) : Supervision enabled, Latching, MAF mapped.
Relay 2 (Evac) : Supervision enabled, Latching, MAF mapped.

Relay 1 = Z1A + Z2A + Z3A + Z4A

Relay 2 = Z4A + V1

V1 = Z1A . Z2A . ^Z5A + Z3A

Where:

Z1 = Detection circuit 1

Z2 = Detection circuit 2

Z3 = Gas Start (LGCS)

Z4 = Gas Released (Pressure Switch)

Z5 = Gas Inhibited

Program the panel as otherwise described in Section 6.2.2.

6.2.7 DRAWINGS

The following drawings are included:

1931-47 1 Zone Gas Flood Door (ME0065-69), Circuit Diagram

1937-2 Local Gas Control Station, Circuit Diagram

1931-123 F3200 AS4428 7U 1 Zone Gas Flood Door Loom/Wiring Diagram

1931-124 F3200 AS4428 1U 1 Zone Gas Flood Panel Loom/Wiring Diagram

1931-132 ME0065-69 Gas Door Mods for AVI Mk2 3-Wire Connections

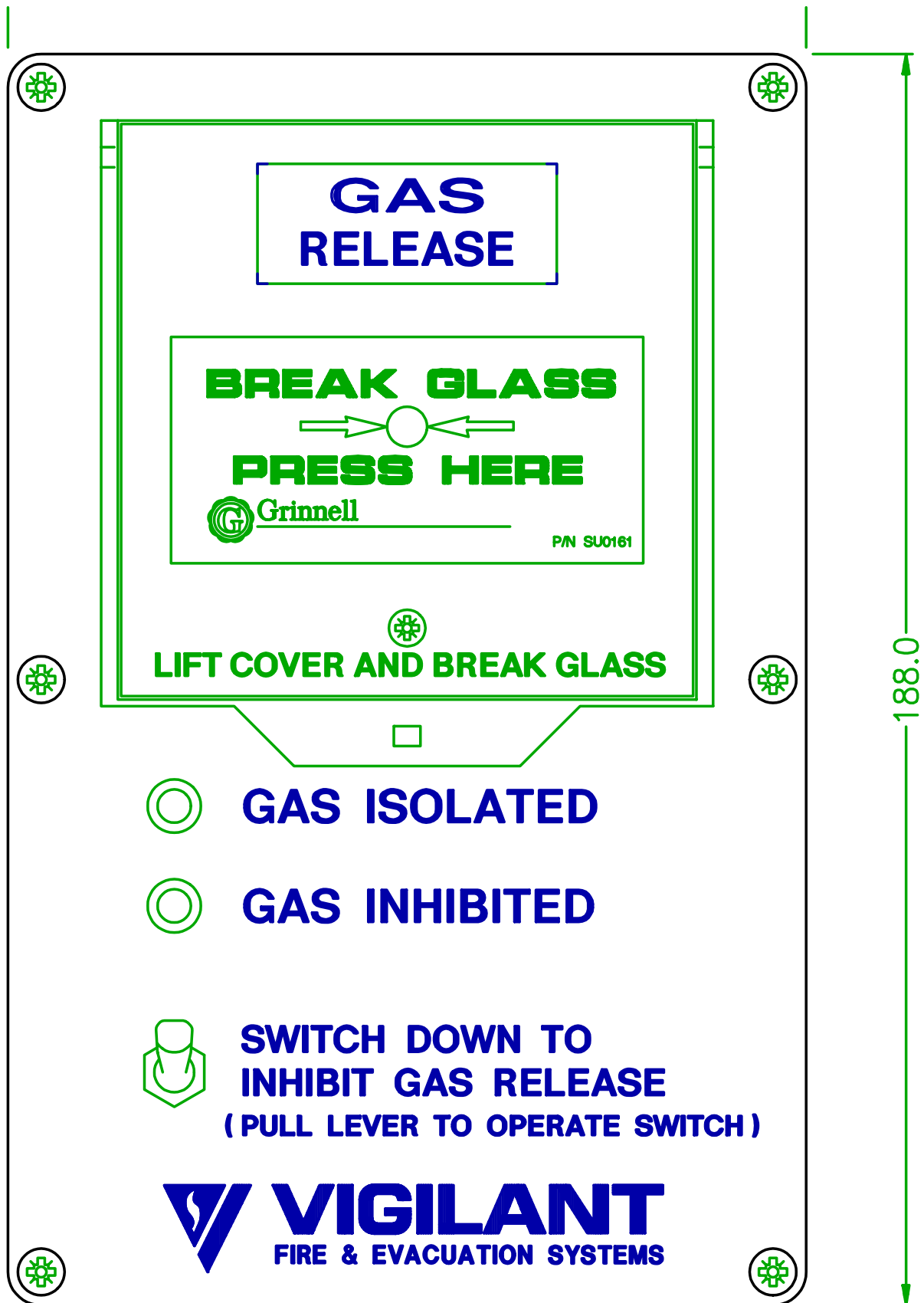

FIG 6.2.6
LOCAL GAS CONTROL STATION, FRONT VIEW

6.3 SUB FIP MONITORING

6.3.1 GENERAL

A sub-FIP is a Fire Indicator Panel (e.g. a Gas Flood Panel) which may not be connected directly to the Brigade, but repeats its common conditions (e.g. Fire, Fault) to another FIP. AS1670.1 allows for the cabling from FIP to sub-FIP to be less than 0.75sqmm, and the resistance may be considerably greater than that used in standard detector circuits. The "Low Current Mode" for an F3200 AZC allows supervision of sub-FIPs on circuits with high resistance.

The limitations caused by the resistance in sub-FIP monitoring circuits are shown in the following 3 cases.

1. Loop Resistance Less than 150 Ohms

For a detector circuit programmed for standard mode the maximum loop resistance is 50 Ohms, but where there is no detector load (i.e. clean contacts are used) the resistance may be up to 150 Ohms.

Therefore it is recommended that for loop circuits of less than 150 Ohms, "standard mode" be used for sub-FIP monitoring.

All voltage bands are potentially usable, but it is recommended that B3 NOT be used for any condition as the circuit voltage drop of up to 2.5V needs to be allowed for. B2 can be used with a 5V6 or 6V8 zener diode to detect Alarm i.e. ZnA, and B1 can be used to detect Alarm (ZnD) or Instant Alarm (ZnM).

2. Loop Resistance of 150 Ohm to 800 Ohm

For this resistance range the AZC has to be programmed into "Low Current Mode", and voltage band B1 should be programmed as Fault or Alarm but must not be used to detect the Fault signal from the sub-FIP (i.e. by shorting the circuit with the Fault contacts). Shorting the circuit at the sub-FIP will cause B2 Alarm.

Because the voltage drop in the circuit wiring is between 3.8V and 12V, depending on loop resistance, it is recommended that B3 not be used to detect a signal (for safety sake it is advisable to program B3 as Alarm and B1 as Alarm or Fault. Note that only a short somewhere within the circuit wiring can cause B1).

3. Loop Resistance of 800 Ohm to 2000 Ohm

For this resistance range the AZC has to be programmed into "low current mode", and the voltage band B3 has to be programmed as Alarm. Shorting the circuit at the sub-FIP will cause either a B2 or B3 Alarm depending on the loop resistance (nominal B2/B3 threshold is 1100 Ohm).

B1 may be programmed as Fault or Alarm, but must not be used to detect the Fault signal from the sub-FIP.

6.3.2 CONNECTION

There are various connection possibilities depending on the particular local requirements for Standby and Isolate, and the loop resistance. One or two AZCs may be required.

Where Standby is required as a separate signal at the Main FIP it can be signalled as Alarm on a second AZC and the corresponding zone programmed as non-MAF, non-Anc1, etc. Isolate could be signalled as "Fault" on the same AZC (ref Fig 6.3.1 and Fig 6.3.2).

CONNECTION (CONTINUED)

The Main FIP Brigade Standby and Isolate relays could be reprogrammed to include the "standby" zone "alarm" and "fault" conditions, or separate module relays could be programmed to operate on the zone "alarm" and "fault" conditions. These would then be connected to the Brigade transmitting device in series/parallel with the Standby and Isolate contacts of the MAF Brigade relays as appropriate.

Note that the EOL required depends on the mode programmed for the AZC.

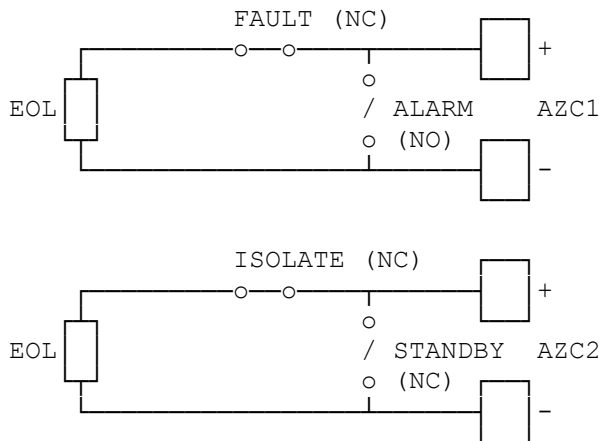
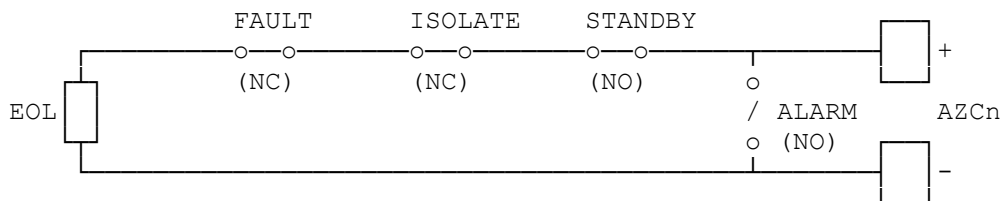
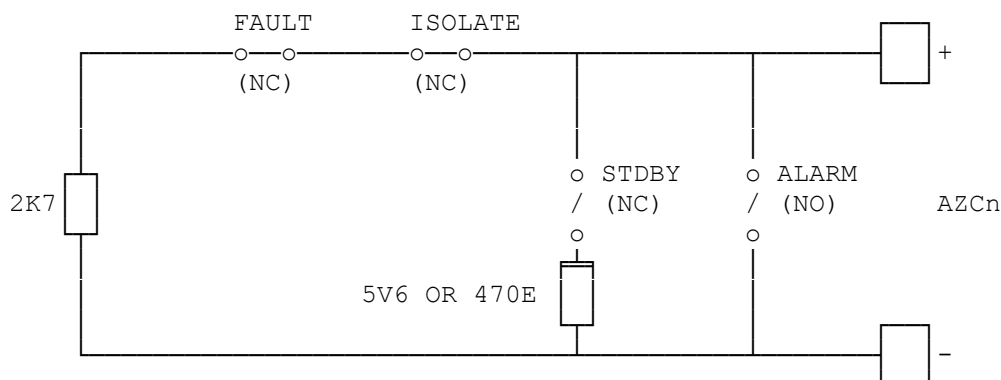

FIG 6.3.1
EXAMPLE OF SUB-FIP MONITORING USING 2 AZCS



Fault, Isolate and Standby are all represented by ZnF in the Main FIP.

FIG 6.3.2
EXAMPLE OF SUB-FIP MONITORING USING 1 AZC



Program B1 as Instant, ZnM represents "Alarm"
ZnD represents "Standby"
ZnF represents "Fault" or "Isolate"

FIG 6.3.3
EXAMPLE OF SUB-FIP MONITORING FOR RESISTANCE CASE 1 ONLY

6.4 FIRE DETECTION IN HAZARDOUS AREAS (EXPLOSIVE ATMOSPHERES)

6.4.1 REFERENCES

AS 2380	Electrical Equipment for Explosive Atmospheres - Explosion-Protection Techniques.
AS 2381	Electrical Equipment for Explosive Atmospheres - Selection, Installation & Maintenance.
AS 2430	Classification of Hazardous Areas.
IEC79	Electrical Apparatus for Explosive Atmospheres.
SAA HB13	Electrical Equipment for Hazardous Areas (handbook).

6.4.2 GENERAL

A hazardous area is one which has a potentially explosive atmosphere due to combustible gases, liquids or dusts. In such an area there has to be a constraint to prevent an electrical fault from causing an explosion.

For fire detection in hazardous areas there are two main options:

- 1) Use approved IS (Intrinsically Safe) detectors and bases with IS isolators or Zener barriers and approved cabling.
- 2) Use approved detectors with explosion proof housings and compatible cabling. (E.g. Olsen V41B, (V42B), V44B, T54B). These are not discussed further in this section as the constraints are primarily mechanical.

Note that in addition to equipment selection and inter-connection, there are other requirements for wiring in hazardous areas that must be satisfied.

These include (but are not limited to):

- Matching "Ex" rating of equipment chosen with hazardous area classification.
- Ensuring cable capacitance and inductance is within the limits of the repeaters used (see Tables 6.4.3, 6.4.4, 6.4.5 for more details).
- Providing adequate physical protection for equipment according to local hazardous area wiring regulations.
- Using cable of the correct insulation and physical strength according to local hazardous area wiring regulations.
- Complying with manufacturer's instructions for mounting of "Ex" rated devices.
- Inspection and certification of the finished installation.

6.4.3 INTRINSICALLY SAFE DETECTION

There are two types of device which may be inserted in a detector circuit between the FIP and the detectors to limit the electrical energy flow into the area and provide IS detection:

- 1) Galvanically (transformer) isolated repeaters (isolators).
- 2) Zener barriers (shunt barriers with fuses). These limit the circuit voltage relative to earth, and the circuit current.

Although Zener barriers are cheaper than isolators they require a special Intrinsic Safety Earth, and precautions, and are therefore not recommended.

6.4.3.1 ISOLATED REPEATERS

There are several options for using isolated repeaters, each with differing limitations and expense.

The options are:

1. Use a 6 terminal isolating repeater where large numbers of smoke and/or flame detectors are required (see Section 6.4.3.2).
2. Use a lower-cost 4 terminal isolating repeater and a ZAU401 (Rev 2) where lower numbers of smoke and/or flame detectors are required (see Section 6.4.3.3).
3. Use a 4 terminal isolating repeater where all detectors generate a short circuit alarm condition (see Section 6.4.3.4).

For these the total capacitance and inductance of the detectors and cables on the IS circuit must be less than that specified in Table 6.4.1. The gases and vapours in each Gas group are listed in IEC 79-12.

GAS GROUP	MAX. CAPACITANCE	MAX. INDUCTANCE
Class IIA or Group D	1.04uF	31.9mH
Class IIB or Group C	0.39uF	12.6mH
Class IIC or Group A or B	0.13uF	3.6mH

TABLE 6.4.1
MAXIMUM CAPACITANCE & INDUCTANCE PER IS CIRCUIT

For isolated repeaters, the cable core to core capacitance can be used, rather than core to earth which, for bunched conductors on metal trays, may be higher. (Note that for Zener barriers, the core to earth capacitance is relevant). The values used in this section for a typical TPS pair, or multicore cable (unshielded) are:

TPS $C = 100\text{nF/km}$ (i.e. 100 pF/m), $L = 0.8\text{mH/km}$

Cable manufacturers may quote differing values for specific cables.

It is the responsibility of the System Engineer to check that the cable used has values less than or equal to the above values, and that the total capacitance and inductance for each circuit meet the requirements.

The values specified for the detectors are shown in Table 6.4.2.

ISOLATED REPEATERS (CONTINUED)

DETECTOR	CAPACITANCE	INDUCTANCE	RESISTANCE (FW ONLY)
C29BEx/Z94C	1nF	1uH (0.001mH)	
R24Bex	3.3nF	1.5mH	
FW68	84nF/km	0.62mH/km	100Ω/km
FW105	66nF/km	0.83mH/km	100Ω/km
FW180	57nF/km	0.89mH/km	100Ω/km
S231i+	1.5nF	0	
S121	4nF	0	
MS302Ex	1.5nF	0	
MF301Ex	1.5nF	0	
MR301Ex (Photo)	1.5nF	0	
MR301TEX (HPO)	1.5nF	0	
T56B (Heat)	0	0	
(Z500N base)	0	0	
T54B (Heat)	0	0	

TABLE 6.4.2
CAPACITANCE & INDUCTANCE PER I.S. DETECTOR

Notes

1. The KHD0-ICS/Ex 251 or KFD0-CS-Ex 2.51P is effectively two KHD0-ICS/Ex 151 or KFD0-CS-Ex 1.51P isolators (respectively) in one package.
2. The resistance quoted in Table 6.4.2 for fire wire is per wire, thus the circuit resistance of the pair is twice that amount.
3. The FW68 and FW105 fire wires are not currently listed as IS.
4. The MS302Ex, MF301Ex, MR301Ex, MR301TEX, S121 and S231i+ detectors are currently not SSL approved.

For each of the following configuration options a table is included showing the limits of detector quantity and cable length.

6.4.3.2 6 TERMINAL ISOLATED REPEATER

The following 6 terminal isolating repeaters can connect an F3200 zone to an IS detection circuit using the circuit of Fig 6.4.3.2. Detector quantities and circuit lengths as shown in Table 6.4.3.

Pepperl & Fuchs KHD3-ICR/Ex130 200
Pepperl & Fuchs KFD2-CR-Ex1.30 200

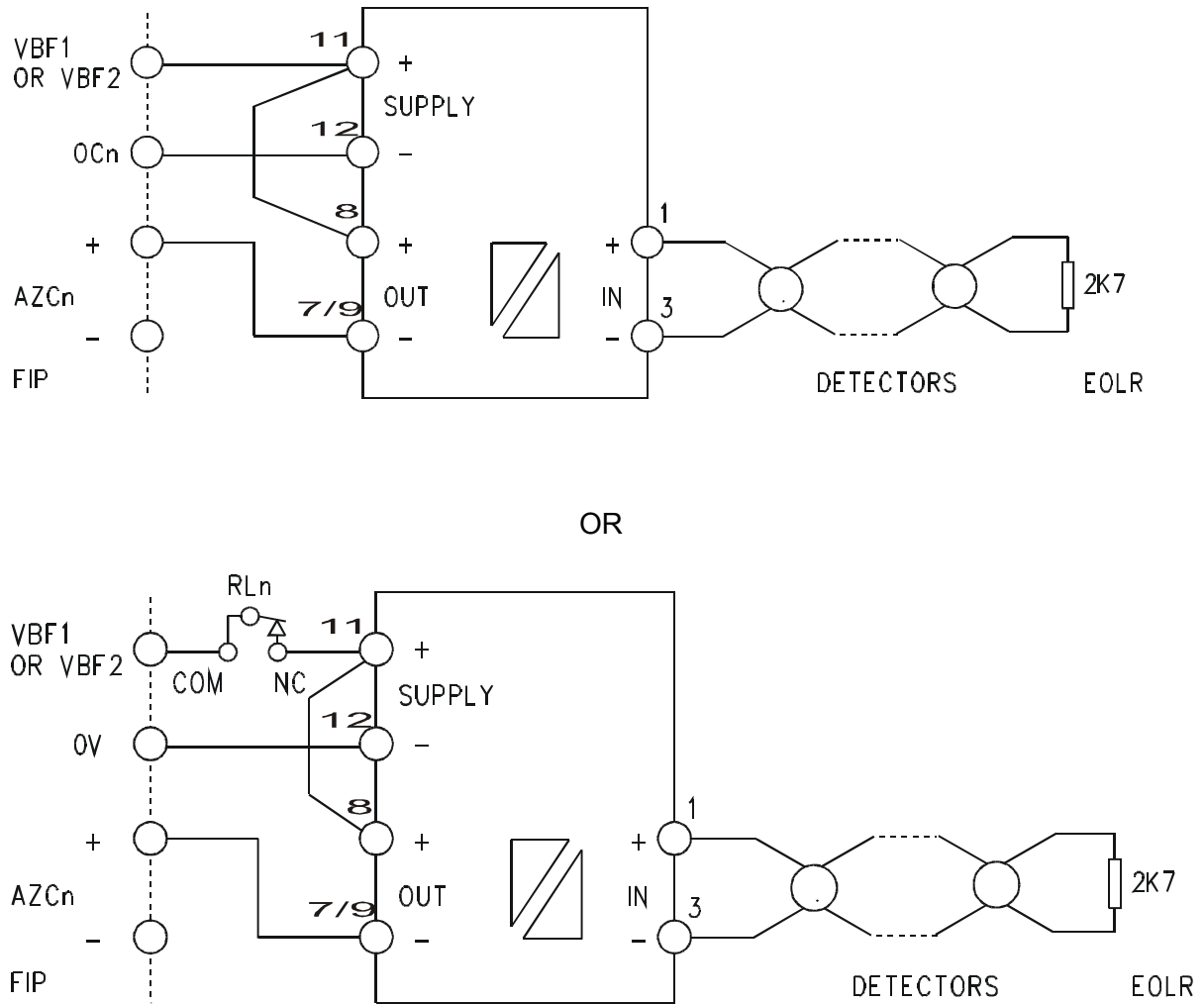

FIG 6.4.3.2
F3200 IS CIRCUIT USING 6-TERMINAL REPEATERS

Relay or Open Collector

For each AZC there must be either: a corresponding relay (e.g. Module Relay RLn) with normally closed contacts breaking the supply to the Isolator as shown; or an open collector output switching the supply 0V as shown. As the open collector is standard with an 8ZM it is the cheapest alternative.

Programming & Limitations

All detector types require the circuit to be programmed for Mode 1 (Std) with voltage band B1 programmed as Alarm.

The open collector must be programmed as OCn = ^ZnR, or the Relay must be programmed as Rn = ZnR (i.e. Zone n not in Reset or Zone n in Reset respectively).

There is no differentiation of voltage bands (B1, B2, B3), i.e. the FIP cannot differentiate between short-circuiting MCP and detector operation on the same circuit.

6 TERMINAL ISOLATED REPEATER (CONTINUED)

Any alarm on the detector circuit (either a short circuit or detector operation) will cause a B1 or a B2 voltage level on the FIP AZC, depending on the battery voltage.

DETECTOR			GAS GROUP 11A OR 11B			GAS GROUP 11C		
TYPE	PART	BASE	QTY	CCT LENGTH		QTY	CCT LENGTH	
				1.0mm ²	0.75mm ²		1.00mm ²	0.75mm ²
SMOKE	C29BEx	Z94C	40(M)	3km(R) (100Ω)	2.2km(R) (100Ω)	40(M)	0.9km(C) (90nF)	0.9km(C) (90nF)
						33	0.97km(C) (97nF)	0.97km(C) (97nF)
						20	1.1km(C) (110nF)	1.1km(C) (110nF)
						1	1.3km(C) (130nF)	1.3km(C) (130nF)
							1.2km(C) (120nF)	1.1km(R) (50Ω)
FLAME	R24BEx	-	7(M)	1.5km(R) (50Ω)	1.1km(R) (50Ω)	2(M)	1.3km TOT (130nF)	1.3km TOT (130nF)
HEAT	FW105	-	-	-	-	-	1.3km TOT (130nF)	1.3km TOT (130nF)
HEAT	T54B	-	40(M)	3km(R) (100Ω)	2.2km(R) (100Ω)	40(M)	1.3km(C) (130nF)	1.3km(C) (130nF)
HEAT	T56B	Z500N	40(M)	3km(R) (100Ω)	2.2km(R) (100Ω)	40(M)	1.13KM(C) (130nF)	1.3km(C) (130nF)
HEAT	S231i+	-	11(M)	3KM (R) (100Ω)	2.2KM (R) (100Ω)	11(M)	1.13km(C) (113nF)	1.13KM(C) (113nF)
						5	1.22km(C) (122nF)	1.22km(C) (122nF)
						1	1.28km(C) (128nF)	1.28km(C) (128nF)
FLAME	S121	-	40(M)	3km(R) (100Ω)	2.2km(R) (100Ω)	32(M)	0.02km(C) (2nF)	0.02km(C) (2nF)
						20	0.5km(C) (50nF)	0.5km(C) (50nF)
						10	0.9km(C) (90nF)	0.9km(C) (90nF)
						1	1.26km(C) (126nF)	1.26km(C) (126nF)
FLAME	MS302Ex	M300	40(M)	3km(R) (100Ω)	2.2km(R) (100Ω)	40(M)	0.7km(C) (70nF)	0.7km(C) (70nF)
						20	1km(C) (100nF)	1km(C) (100nF)
						1	1.28km(C) (128nF)	1.28km(C) (128nF)
ION	MF301Ex	M300	40(M)	(SAME AS MS302Ex)				
PHOTO	MR301Ex	M300	40(M)	(SAME AS MS302Ex)				
HPO	MR301TEEx	M300	40(M)	(SAME AS MS302Ex)				

**TABLE 6.4.3
MAXIMUM DETECTOR QUANTITY & CABLE LENGTH FOR 6-TERMINAL REPEATER**

Notes

1. Circuit lengths quoted are from the isolator to the EOL. An extra 50 Ohms of cable from the FIP to the isolator is also allowed (1.5km of 1.0mm², 1.1km of 0.75mm²). The length quoted is the maximum for the corresponding quantity of detectors.
2. Cable resistance shown is for the circuit, i.e. both cables in the pair. The value of 34Ω per km (return) is used for 1 mm².
3. The maximum resistances shown for the fire wire circuits must include both cable and fire wire (see Table 6.4.2 and associated note 2).
4. The letter in () after the cable length, and the value in () under the cable length specify which parameter out of capacitance (C), inductance (L) and resistance (R) provides the limitation, and what the maximum value is.

TERMINAL ISOLATED REPEATER (CONTINUED)

5. The (M) after a detector quantity indicates the maximum quantity allowed per circuit.
6. The maximum allowable detector quiescent (or 2 second switch on) current is 3.5mA (only relevant to R24BEx).

6.4.3.3 4 TERMINAL ISOLATED REPEATER WITH ZONE ADAPTOR UNIT ZAU401

With the addition of the ZAU401 Zone Adaptor Unit (PA0838), lower-cost 4-terminal isolating repeaters can be used with the F3200 panel.

The ZAU401 can be thought of as a single zone circuit module that can be added to a panel to make it compatible with a wider range of detectors – in particular when using IS repeaters. It can support up to 2mA of quiescent detector current and uses a 3k9 5% EOL resistor.

Wiring of the ZAU401 and the isolating repeater to the panel is shown in Fig 6.4.3.3. Note that only one ZAU401 can be connected to each of the panel's zone circuits.

The following 4-terminal isolating repeaters can be used to connect the ZAU401 to an IS detection circuit. (Note that dual channel repeaters have two separate repeaters, and can connect two circuits with two ZAU401s). Detector quantity and circuit lengths are shown in Table 6.4.4.

Pepperl & Fuchs	KHD0-ICS/Ex 1.51 (single channel)
Pepperl & Fuchs	KHD0-ICS/Ex 2.51 (dual channel)
Pepperl & Fuchs	KFD0-CS-Ex 1.51P (single channel)
Pepperl & Fuchs	KFD0-CS-Ex 2.51P (dual channel)
Measurement Technology Ltd	MTL5061 (dual channel)

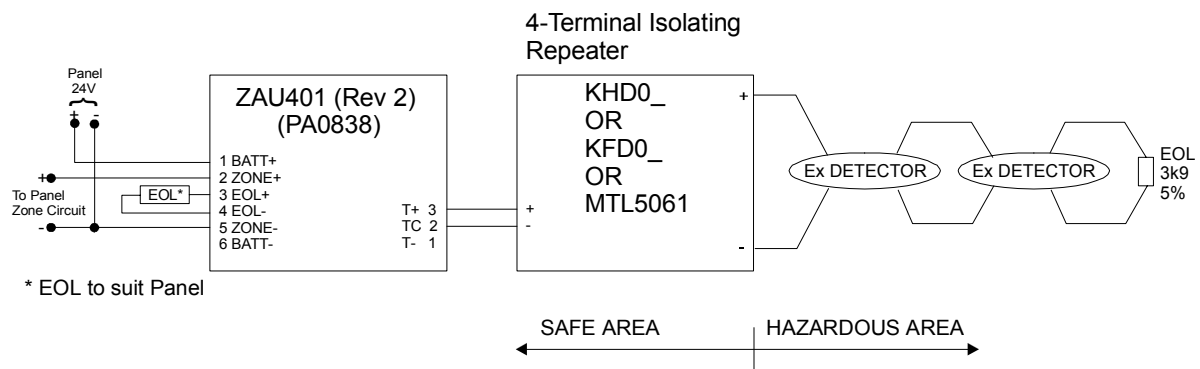

FIG 6.4.3.3
F3200 WITH ZAU401 & 4 TERMINAL IS REPEATER

Programming & Limitations

The circuit should be programmed as Mode 1 (standard). Voltage bands B1 and B3 can be left at default, though it is better to program B1 as fault.

Note that all alarms from the ZAU401 will give voltage band B2 i.e. the FIP cannot differentiate between short-circuiting MCP and detector operation, and voltage B1 represents a short on the circuit between the FIP and the ZAU401 (i.e. internal wiring fault).

**4 TERMINAL ISOLATED REPEATER WITH ZONE ADAPTOR UNIT ZAU401 (REV 2)
(CONTINUED)**

DETECTOR			GAS GROUP 11A OR 11B			GAS GROUP 11C		
			QTY	CCT LENGTH		QTY	CCT LENGTH	
TYPE	PART	BASE		1.0mm ²	0.75mm ²		1.00mm ²	0.75mm ²
SMOKE	C29BEx	Z94C	40(M)	3km(R) (100Ω)	2.2km(R) (100Ω)	40(M)	0.9km(C) (90nF)	0.9km(C) (90nF)
						33	0.97km(C) (97nF)	0.97km(C) (97nF)
						20	1.1km(C) (110nF)	1.1km(C) (110nF)
						1	1.3km(C) (130nF)	1.3km(C) (130nF)
FLAME	R24BEx	-	2(M)	0.5km(R) (17Ω)	.37km(R) (17Ω)	2(M)	0.5km(C) (17Ω)	0.37km(R) (17Ω)
HEAT	FW105	-	-	-	-	-	1.3km TOT (130nF)	1.3km TOT (130nF)
HEAT	T54B	-	40(M)	3km(R) (100Ω)	2.2km(R) (100Ω)	40(M)	1.3km(C) (130nF)	1.3km(C) (130nF)
HEAT	T56B	Z500N	40(M)	3km(R) (100Ω)	2.2km(R) (100Ω)	40(M)	1.13km(C) (130nF)	1.3km(C) (130nF)
HEAT	S231i+	-	4(M)	3KM (R) (100Ω)	2.2KM (R) (100Ω)	4(M)	1.24KM(C) (124nF)	1.24KM(C) (124nF)
FLAME	S121	-	16(M)	3km(R) (100Ω)	2.2km(R) (100Ω)	16(M)	0.66km(C) (66nF)	0.66km(C) (66nF)
						10	0.9km(C) (90nF)	0.9km(C) (90nF)
						1	1.26km(C) (126nF)	1.26km(C) (126nF)
FLAME	MS302Ex	M300	16(M)	3km(R) (100Ω)	2.2km(R) (100Ω)	16(M)	1.06km(C) (106nF)	1.06km(C) (106nF)
						10	1.15km(C) (115nF)	1.15km(C) (115nF)
						1	1.28km(C) (128nF)	1.28km(C) (128nF)
ION	MF301Ex	M300	16(M)	(SAME AS MS302Ex)				
PHOTO	MR301Ex	M300	16(M)	(SAME AS MS302Ex)				
HPO	MR301TEEx	M300	16(M)	(SAME AS MS302Ex)				

**TABLE 6.4.4
MAXIMUM DETECTOR QUANTITY & CABLE LENGTH FOR
ZAU401 (REV 2) & 4-TERMINAL REPEATER**

Notes

1. Circuit lengths quoted are total from the FIP to the EOL. The length quoted is the maximum for the corresponding quantity of detectors.
2. Cable resistance shown is for the circuit, i.e. both cables in the pair. The value of 34Ω per km (return) is used for 1 mm².
3. The maximum resistances shown for the fire wire circuits must include both cable and fire wire (see Table 6.4.2 and associated note 2).
4. The letter in () after the cable length, and the value in () under the cable length specify which parameter out of capacitance (C), inductance (L) and resistance (R) provides the limitation, and what the maximum value is.
5. The (M) after a detector quantity indicates the maximum quantity allowed per circuit.
6. The maximum allowable detector quantity corresponds to a quiescent current of 1.8mA for C29BEx, 0.3mA for R24BEx.

6.4.3.4 4 TERMINAL ISOLATED REPEATER ALONE

When all the detectors on the IS circuit will generate a short circuit alarm condition it is possible to use the lower-cost, 4-terminal isolating repeater without a ZAU401. This is shown in Fig 6.4.3.4.

The following 4-terminal isolating repeaters can be used. (Note that dual channel repeaters have two separate repeaters, and can connect two circuits to the panel).

Pepperl & Fuchs	KHD0-ICS/Ex 1.51 (single channel)
Pepperl & Fuchs	KHD0-ICS/Ex 2.51 (dual channel)
Pepperl & Fuchs	KFD0-CS-Ex 1.51P (single channel)
Pepperl & Fuchs	KFD0-CS-Ex 2.51P (dual channel)
Measurement Technology Ltd	MTL5061 (dual channel)

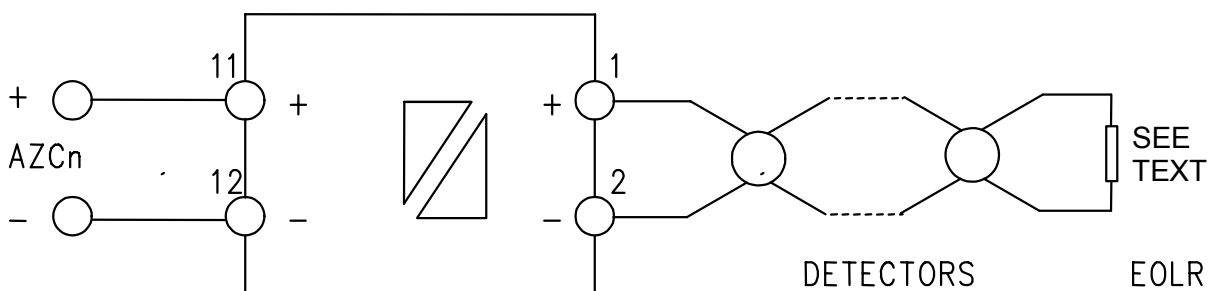

FIG 6.4.3.4
SHORT-CIRCUITING DETECTORS WITH 4 TERMINAL REPEATER

Programming & Limitations

The required EOL resistance is lower than the standard 2k7. Two methods for obtaining the correct EOL value are:

1. Place a 22K 5% resistor in parallel with the supplied 2k7 EOL. This achieves the required value.
2. Or just use a 2k2 5% resistor as the EOL.

The circuit should be programmed as Mode 1, B3 as Normal, and B1 should be programmed as Fault.

There can be no differentiation between short-circuiting MCP and detector operation on the same circuit.

Detector quantity and circuit length limits are shown in Table 6.4.5.

4 TERMINAL ISOLATED REPEATER ALONE (CONTINUED)

DETECTOR			GAS GROUP 11A OR 11B			GAS GROUP 11C		
TYPE	PART	BASE	QTY	CCT LENGTH		QTY	CCT LENGTH	
				1.0mm ²	0.75mm ²		1.00mm ²	0.75mm ²
HEAT	FW105	-	-	NOTE 2 & 3 (68Ω TOT)	NOTE 2 & 3 (68Ω TOT)	-	1.3km TOT (130nF)	1.3km TOT (130nF)
HEAT	T54B	-	40(M)	2km(R) (68Ω TOT)	1.5km(R) (68Ω)	40(M)	1.3km(C) (130nF)	1.3km(C) (130nF)
HEAT	T56B	Z500N	40(M)	2km(R) (100Ω)	1.5km(R) (68Ω)	40(M)	1.3km(C) (130nF)	1.3km(C) (130nF)

**TABLE 6.4.5
MAXIMUM DETECTOR QUANTITY & CABLE LENGTH FOR 4 TERMINAL
REPEATER ALONE**

Notes

1. Circuit lengths quoted are from the isolator to the EOL. The length quoted is the maximum for the corresponding quantity of detectors.
2. Cable resistance shown is for the circuit, i.e. both cables in the pair. The value of 34Ω per km (return) is used for 1 mm².
3. The maximum resistances shown for the fire wire circuits must include both cable and fire wire (see table 6.4.2 and associated note 2).
4. The letter in () after the cable length, and the value in () under the cable length specify which parameter out of capacitance (C), inductance (L) and resistance (R) provides the limitation, and what the limiting value is.
5. The (M) after a detector quantity indicates the maximum quantity allowed per circuit.

6.5 USE OF NORMALLY CLOSED CONTACTS

There may be some situations where it is necessary to monitor a set of normally-closed contacts which open on "alarm".

As standard these cannot be wired directly to the F3200 AZC terminals.

The Vigilant Contact Conversion Module (part number PA0443) may be used as a conversion interface between the contacts and an F3200 AZC.

This small, encapsulated module has three wires protruding from it.

These must be connected between the normally closed contact and the AZC as shown in Fig 6.5.1, using suitable screw terminal blocks.

The module applies a low impedance to the AZC when the alarm contacts open, and so the circuit must be programmed as B1 = Alarm.

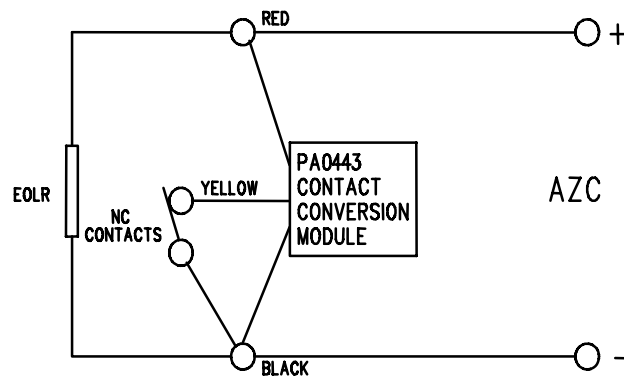

FIG 6.5.1
NORMALLY CLOSED CONTACT WIRING TO F3200 AZC

6.6 SPECIAL CONNECTIONS TO DETECTORS

6.6.1 CONNECTING THE S231I+ OR S231F+ (USING ZAU401 REV 2)

**** WARNING ****

Even though the S231i+ is listed as hazardous area rated, this compatibility is for a direct connection – not through an intrinsically-safe isolator, and thus cannot be used in hazardous area applications. For IS applications refer to Section 6.4.

The S231i+ and S231f+ detectors are not directly compatible with the F3200. However, compatibility can be achieved by using the PA0838 ZAU401 (Rev 2) Zone Adaptor unit between the panel and the detectors.

The ZAU401 can be thought of as a single zone circuit module that can be added to a panel to make it compatible with a wider range of detectors. The ZAU401 supports up to 2mA of quiescent detector current, thus only 5 S231i+ or S231f+ detectors can be used on each ZAU401. It operates off the panel's 24V supply and consumes 20mA in the normal state.

Only one ZAU401 can be connected to each circuit on the panel. Also, do not use a Rev 1 or non-Vigilant manufactured ZAU401 as these have different characteristics.

A 220E 5W resistor (Vigilant part number RR0415) must be placed in series with the detector circuit at the ZAU401 to limit the maximum current to any detectors in alarm.

Wiring of the ZAU401 to the panel and S231i+ or S231f+ detectors is shown in Fig 6.6.1.1.

* EOL to suit Panel used.

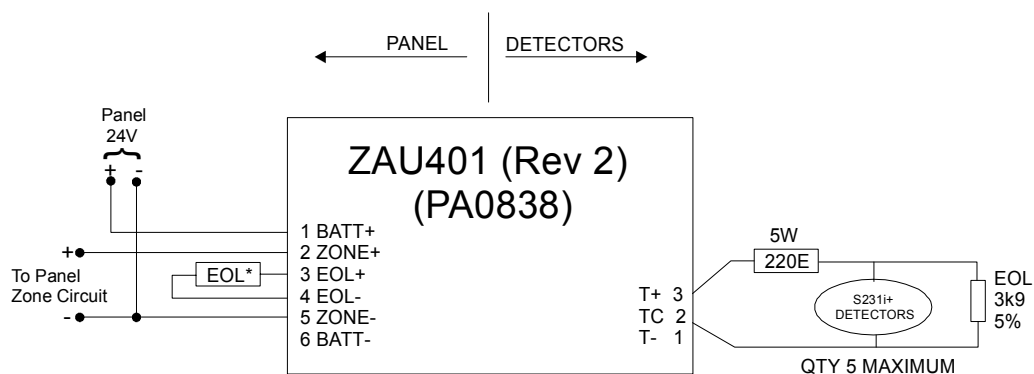

**FIG 6.6.1.1
ZAU401 (REV 2) AND S231I+ or S231F+**

CHAPTER 7 ALIGNMENT, ADJUSTMENT & PLACING INTO OPERATION

7.1 ALIGNMENT & ADJUSTMENT

All the F3200 modules (pcbs) are tested and aligned in the factory before being supplied to the customer or fitted to a FIP. The only field adjustments that may be necessary are to set the LCD contrast and the battery charger voltage.

Controller/Display

VR2 LCD Contrast Adjust for best readability of the LCD when viewed from the front of an installed panel.

Factory adjustments include:

VR1 Set 1.2V Ref Adjust for Charger High voltage of 28.1V to 28.15V.

VR3 Adjust 15.9V Adjust until the 15.9V reference on TP15 is 15.90Vdc.

R94, R105 Fault Threshold Snip as required to set Fault Threshold to nominal 19.03V.

MAF/PSU

PT1 Battery Charger Voltage

Should the battery charger voltage need adjusting, the method is as follows:

1. Run the system with the door closed for at least 30 minutes to allow components to "warm up" (the longer the better).
2. Calculate the required no-load battery charging voltage by taking 27.3V for 20°C and subtracting approximately 0.1V for every 3°C above 20°C, or adding approximately 0.1V for every 3°C below 20°C.
3. With the system not in Alarm, disconnect the batteries.
4. Measure the voltage at the battery terminals and adjust to the voltage calculated in Step 2 by turning PT1.
5. Re-connect the batteries.

PT2 +22V Supply is factory set and should not need field adjustment.

7.2 PLACING INTO OPERATION

7.2.1 GENERAL

This chapter describes the procedure to place an F3200 FIP into operation. It assumes that the mains and other field wiring has been connected, but that the battery has not and the mains is not yet switched on. Note that all electronic modules were tested and adjusted in the factory and should need no further adjustment.

Before switching on power (mains), inspect the cabinet and internals. Check as follows:

1. Check that all equipment is securely mounted, and that all cables are connected at the appropriate points. The factory checklist is included.
2. Check that the 8 way modules and (if required) the 16 Zone LED Displays are fitted and connected correctly. (See Sections 2.3.2, 4.2 and 5.11).
3. Check that any additional overcurrent protection device is fitted as per Chapter 4. Note that batteries are not yet connected.
4. Check that links Lk2-4 on the MAF are fitted (unless Anc3, clean contacts is being used), and module relay supervision links are fitted in the S position for relays which require supervision.
5. Check that the field wiring of AZC and relays is as per the "As Built" wiring diagrams and corresponds to the configuration of modules and links.

The "MAINS ISOLATE SWITCH" is located at the top right hand side of the cabinet rear, to the left of the mains transformer, behind the inner display door. This controls the mains power to the FIP, charger and power supply, and should be left on once the FIP is operational.

NOTE: The Battery is not disconnected by the "MAINS ISOLATE SWITCH".

7.2.2 POWER UP

To place the F3200 FIP into operation, perform the following steps:

- STEP 1 Ensure that the Mains Isolate Switch is OFF.
- STEP 2 Ensure that 240 VAC is connected to the panel from the mains distribution switchboard.
- STEP 3 Ensure that LK7 on the controller is set to the DATABASE WRITE PROTECT position before powering on the panel. If an E2INIT is required before programming, fit Minijump SW1. (Refer to the Programming Manual).
- Turn the Mains Isolate Switch ON.
- STEP 4 Check that the buzzer sounds and all LEDs on the Operator Display panel flash for 2 seconds (except Mains On).
- STEP 5 Check that the green "MAINS ON" LED indicator is on.
 The Controller performs tests on its memory, electronics, and the LCD.
- STEP 6 Check that the LCD has good visibility. The LCD displays the FIP PCB configuration before showing the Base Display.
- STEP 7 If doing an E2INIT, set LK7 to the DATABASE WRITE position, remove minijump SW1 and press "ACK" to complete the sequence.
- STEP 8 Install and connect the batteries.
 Take care not to short the battery leads or connect in reverse polarity when connecting.
- STEP 9 If required, complete programming as per the Programming Manual and then fit Lk7 on the Controller to the DATABASE PROTECT position.
- STEP 10 Perform a Battery Test.
 - If this fails check the battery connections, leave for 24 hours and then retest.
- STEP 11 Perform a System Test (de-isolate all zones first), and a test of the External Bell and Warning System (if fitted).

A full commissioning test should be carried out as per AS1670.1.

7.2.3 COMMISSIONING CHECKLIST

The following checklist should have been completed and supplied by the manufacturer. It should be placed with other System Configuration Information. Commissioning staff should check the installed FIP against it. (Note that all pcbs are electronically tested and adjusted before being fitted to the FIP).

1. CABINET & GENERAL

- | | | |
|----|--|--------------------------|
| A) | Cabinet colour - Standard Cream Wrinkle (BFF 998 CW)
- Other: _____ | <input type="checkbox"/> |
| B) | Cabinet undamaged (Paint OK) | <input type="checkbox"/> |
| C) | Door aligned correctly | <input type="checkbox"/> |
| D) | Window undamaged and fitted correctly | <input type="checkbox"/> |
| E) | MCP fitted and undamaged | <input type="checkbox"/> |
| F) | Cabinet Door locks firmly, operates microswitch | <input type="checkbox"/> |
| G) | Lock - 003 Type & two keys supplied | <input type="checkbox"/> |
| H) | Door seals fitted to top and sides | <input type="checkbox"/> |
| I) | Display Keypad and 4U door fitted & aligned correctly | <input type="checkbox"/> |
| J) | Cardframe fitted, card fits frame correctly ..(FP0551 only) | <input type="checkbox"/> |
| K) | Standoffs fitted to cabinet rear (none missing) | <input type="checkbox"/> |
| L) | Operator Manual and battery leads included | <input type="checkbox"/> |
| M) | Manufacturer's label completed, fitted | <input type="checkbox"/> |

2. PCBS & WIRING

- | | | |
|----|--|--------------------------|
| A) | MAF/PSU Fitted securely on standoffs | <input type="checkbox"/> |
| B) | Controller/Display fitted securely | <input type="checkbox"/> |
| C) | 8ZM fitted securely, earth screw fitted | <input type="checkbox"/> |
| D) | FRC Looms fitted correctly | <input type="checkbox"/> |
| E) | MCP & door switch wires fitted to J6 of MAF/PSU, secured | <input type="checkbox"/> |
| F) | Earth wire fitted to display door | <input type="checkbox"/> |
| G) | All 3 modules earth to cabinet metal | <input type="checkbox"/> |

COMMISSIONING CHECKLIST (CONTINUED)

3. POWER SUPPLY

- A) Mains Wired correctly, MOV, cap fitted
- B) "Mains Isolate Switch" and "NAE" label fitted
- C) Mains Earth wired to stud, good contact
- D) Mains Switch neon off/on for switch off/on
- E) MAF/PSU Mains On LED on, Fuse Blown LED off
- F) VRECT at DC IN tab 40-42Vdc
- G) Charger Voltage 27.25-27.4V warm, 27.5-27.75V cold

4. OPERATION

- A) LEDs flash, aligned with windows, "MAINS ON" LED on
- B) Buzzer pulses with microswitch operated, Lk7 in Write
- C) Controller LK7 in "Protect" position
- D) LCD contrast correct for front view
- E) De-isolate zones, system test pass on all (8) circuits
- F) FIP MCP Programmed to Zone 1; Other: _____ OK
- G) "ALM" LED flashes & buzzer pulses for MCP operation
- H) Acknowledge silences buzzer, Zone Resets
- I) Controller Lk2 fitted (not in Service mode)

SERIAL NUMBER TEST PASSED

DATE : SIGNATURE :

7.3 ERROR MESSAGES FOR STARTUP

Listed below are some error messages that can appear on the LCD during installation. Refer also to Section 6.16 System Faults in the Operator Manual LT0250.

Error messages that can occur on startup or exit from program mode

"Shift reg clocking fault"

"Invalid # shift regs.Total # regs=xxx # input regs=xxx"

These messages indicate a hardware fault with the shift register bus that connects the Controller, MAF/PSU, 8 Zone, and 8 Relay modules. The fault could be on the Controller, the interconnecting FRCs or any of the connected boards. Try connecting just the MAF/PSU on its own and with different cables to isolate the problem.

"Shift reg driver fault"

This message indicates a problem with the software driver for the shift register bus.

"Clock crystal timebase check fail"

This message indicates a hardware fault on the Controller.

"Clock chip ram write read fail"

"Clock register write read fail"

"Clock startup fault"

These messages indicate a hardware fault on the Controller.

"Eprom CRC fail"

This message indicates the checksum of the software program code is incorrect. This can be caused by a damaged EPROM or some other hardware fault on the Controller.

Error messages that can occur on entry to program mode

"This database is invalid and should be reinitialised-net dbase in non net panel"

This message is produced on entry to program mode when a database created with networked F3200 or NDU software is used with non-networked software. This is unusable and the database should be re-initialised and reprogrammed.

APPENDIX A1

COMPATIBLE ACTUATING DEVICES (DETECTORS)

The following detectors are compatible with the F3200 System. The maximum number of detectors per circuit is indicated by the columns 4mA and IS, for Standard and Intrinsically Safe applications. For IS application refer to Section 6.4.

DETECTORS CERTIFIED WITH F3200 FIP			MAX NO.	
TYPE		DESCRIPTION	4mA	IS
MD614A		HEAT DETECTOR TYPE A	40	-
MD614C		HEAT DETECTOR TYPE C	40	-
MF614		IONISATION SMOKE DETECTOR	40	-
MR614		PHOTOELECTRIC SMOKE DETECTOR	40	-
MR614T		PHOTOELECTRIC SMOKE DETECTOR	40* ¹	-
MU614		CO FIRE DETECTOR	40	-
T614A		HEAT DETECTOR TYPE A	40* ²	-
T614B		HEAT DETECTOR TYPE B	40* ²	-
T614C		HEAT DETECTOR TYPE C	40* ²	-
T614D		HEAT DETECTOR TYPE D	40* ²	-
MF301Ex	x	IONISATION SMOKE DETECTOR	40	40
MR301Ex	x	PHOTOELECTRIC SMOKE DETECTOR	40	40
MR301TEx	x	PHOTOELECTRIC SMOKE DETECTOR	40	40
MS302Ex	x	INFRA-RED FLAME DETECTOR	40	40
S111	x	INFRA-RED FLAME DETECTOR (IS)	-	35
S121	x	INFRA-RED FLAME DETECTOR (IS)	-	35
S131	x	INFRA-RED FLAME DETECTOR (IS)	-	35
S231i+	x	INFRA-RED FLAME DETECTOR (IS)	-	11
S231i+		INFRA-RED FLAME DETECTOR AND ZAU401	5	5
S231f+		INFRA-RED FLAME DETECTOR AND ZAU401	5	-
S261f+		INFRA-RED FLAME DETECTOR	40	-
SU0600		15V MCP	40	-

*¹ For ambient temp < 30°C. Max Qty is 34 otherwise

*² 47E resistor required between AZC+ and detector +ve. See PBG0116.

Table I MINERVA/THORN Detectors

DETECTORS CERTIFIED WITH F3200 FIP		MAX NO.
TYPE	DESCRIPTION	4mA
DCA-B-60R	HEAT DETECTOR TYPE A	40
DCA-B-90R	HEAT DETECTOR TYPE C	40
DCD-A	HEAT DETECTOR TYPE A WITH YBO – R/4A BASE	40
DCD-C	HEAT DETECTOR TYPE C WITH YBO – R/4A BASE	40
DFE-60B	(DFB-60B) HEAT DETECTOR TYPE B	40
DFE-90D	(DFB-90B) HEAT DETECTOR TYPE D	40
DFJ-60B	HEAT DETECTOR TYPE B WITH YBO – R/4A BASE	40
DFJ-90D	HEAT DETECTOR TYPE D WITH YBO – R/4A BASE	40
SIJ-ASN	IONISATION SMOKE DETECTOR WITH YBO – R/4A BASE	40
SLR-AS	PHOTOELECTRIC SMOKE DETECTOR WITH YBO – R/4A BASE	40
SIF-AM	IONISATION SMOKE DETECTOR	40
SIH-AM	IONISATION SMOKE DETECTOR	40
SLK-A	PHOTOELECTRIC SMOKE DETECTOR	40
SLG-AM	PHOTOELECTRIC SMOKE DETECTOR	40
HF-24A	ULTRAVIOLET FLAME DETECTOR	18
WITH YBC-RL/4AH4, YBF-RL/4AH4 OR YBF-RL/4AH4M BASES		

Table II HOCHIKI Detector Range

DETECTORS CERTIFIED WITH F3200 FIP			MAX NO.	
TYPE	DESCRIPTION	BASE	4mA	IS
B111B #	BEAM SMOKE DETECTOR (NOTE 7)	-	40	0
B21B	BEAM SMOKE DETECTOR	-	1	0
C23B *&	IONISATION SMOKE DETECTOR	Z23	40	0
C23Bex *x	IONISATION SMOKE DETECTOR (IS)	Z23	40	35
C24B	IONISATION SMOKE DETECTOR	*1	40	0
C29B	IONISATION SMOKE DETECTOR	*1	40	0
C29BEX x	IONISATION SMOKE DETECTOR (IS)	Z94C	40	40
DL01191A	BEAM DETECTOR	-	1	-
FW81B	HEAT DETECTOR CABLE FW68, FW105 (IS)	-	1000m	1000m
P24B	PHOTOELECTRIC SMOKE DETECTOR	*1	40	0
P29B	PHOTOELECTRIC SMOKE DETECTOR	*1	36	0
P61B *	PHOTOELECTRIC SMOKE DETECTOR (REV J)	-	40	0
P76B	PHOTOELECTRIC SMOKE DETECTOR NON-LATCHING	Z72	10	0
P136	DUCT SAMPLING UNIT	-	8	-
R23B &	INFRARED FLAME DETECTOR	-	36	0
R24B	DUAL SPECTRUM INFRARED FLAME DETECTOR	-	8	0
R24BEX +x	DUAL SPECTRUM INFRARED FLAME DETECTOR (IS)	-	8	7
T54B +x#	PROBE TYPE E HEAT DETECTOR (IS OR FLAMEPROOF)	-	40	40
T56B x	HEAT DETECTOR TYPES A, B, C, D (IS WITH Z55, Z56N or Z500N BASE)	*1	40	40
V41B +x#	ULTRAVIOLET FLAME DETECTOR	-	40	40
V42B +x#	ULTRAVIOLET FLAME DETECTOR SLAVE	-	N/A	N/A
V44B +x#	ULTRAVIOLET FLAME DETECTOR	-	40	40
-	SHORT CIRCUIT DEVICE	-	40	40
ZAU401	ZONE ADAPTOR UNIT	-	1	-
*1 = Z54, Z54 MK2, Z55B, Z56, Z500 BASES				

Table III
OLSEN Detector Range

DETECTORS CERTIFIED WITH F3200 FIP		MAX NO.
TYPE	DESCRIPTION	4mA
SERIES 60	APOLLO HEAT DETECTOR TYPES A, B, C, D	40
SERIES 60	APOLLO PHOTOELECTRIC SMOKE DETECTOR	40
SERIES 60	APOLLO IONISATION SMOKE DETECTOR	40
ALL WITH 45681-200 BASES		
MK VIII *	FLAMEGUARD HEAT DETECTOR TYPE A	22
MK VIII *	FLAMEGUARD HEAT DETECTOR TYPE C	11
MK5, MK6 *	INTERTEC HEAT DETECTOR TYPES A, B, C, D	22
(NOTE 9) DETECTOR HAS INTEGRAL LED & TERMINALS		

Table IV
OTHER Detectors

SIMPLEX RANGE			MAX NUMBER WITH EOL	
TYPE	DESCRIPTION	Iq uA		
4098-9618EA	Type A Heat Detector	100	40* ²	
4098-9619EA	Type B Heat Detector	100	40* ²	
4098-9621EA	Type D Heat Detector	100	40* ²	
4098-9601EA	Photoelectric Smoke Detector	100	40	
4098-9603EA	Ionisation Smoke Detector	100	40	

*¹ All with Simplex 4098-9788EA base.

*² 47E resistor required between AZC+ and detector +ve. See PBG0116.

Table V
SIMPLEX Detectors

REMOTE INDICATORS (LEDS) WITH COMPATIBLE DETECTORS/BASES										
REM IND/ BASE	Z51 B	Z52B	Z54B	Z54B MK2	Z55B	Z56	Z500	Z91C	Z94C	MUB
E500	✓		✓					✓	✓	
E500 MK2				✓		✓	✓	✓	✓	✓

DET/REM IND	E500	E500 MK2
C23B	✓	
R23B	✓	✓
R24B	✓	✓
P76B	✓	✓

Table VI
Tyco Detector/Base & Remote LED Range

The E500 remote indicators are designed to operate across typically 5V.

E500 R = 180Ω, V_F LED = 2.2V typical

E500 Mk2 R = 1.2kΩ, V_F LED = 1.75V typical

**ACTUATING DEVICE COMPATIBILITY
NOTES**

- 1) The maximum number of detectors per AZC allowed by the standard is 40.
- 2) Those detectors shown in brackets are old models and have the same characteristics as the current models.
- 3) Detectors indicated by a "x" may be used in INTRINSICALLY SAFE AREAS in conjunction with approved and compatible, intrinsically safe adaptors. The number allowed in a particular circuit may be less than the maximum shown. See Section 6.4.

V41/42/44B detectors have flameproof enclosures.
- 4) Detectors indicated by a "+", which are used in HOSTILE CLIMATIC ENVIRONMENTS, may be directly connected to the panel, if they are not required to be intrinsically safe.
- 5) Detectors indicated by a "*", are not current models and should not be used for new installations.
- 6) Detectors indicated by an "&", normally use an incandescent lamp which will have a low intensity when used in mode 1.

The lamp can be replaced with an LED kit.
- 7) The B111B beam and V41B/V42B/V44B flame detectors require power from the fused +24 VDC supply.
- 8) Hard Contact devices are indicated by a "#". Where an AZC has only hard contact detectors the circuit resistance may be up to 150 Ohms maximum to guarantee voltage band B1 operation.
- 9) There is a 12V version of Flameguard which may be used by adding a Zener diode. The Intertec detectors require a series diode to be fitted for compatibility. Both of these are detailed in Product Bulletin PBF0080.
- 10) The Olsen FW81B code for fire wire has been replaced by FW followed by the temperature rating in °C, e.g. FW68, FW105. Only FW68 is currently approved and listed.

APPENDIX A2

PROGRAMMING FOR DETECTOR TYPE

1. GENERAL

The default programming (i.e. by E2-INIT) for AZCs (circuits) and zones is:

Circuits

Alarm Text	Mode	Delay (Type)	Voltage Band B1 (0-3V)	Voltage Band B3 (13-17.5V)
1 Smoke	1 Standard	1 Standard	1 Instant Alarm	1 Instant Alarm

Zones

Latch/Non-Latch	Mapped/Not to MAF	Mapped/Not to Anc 1	Mapped/Not To Warning System	Mapped/Not To Ext Bell	LED Map (Zone n)
Latch	Mapped	Mapped	Mapped	Mapped	LED n

The default "circuit" programming suits most of the common "electronic" (as opposed to "hard contact") smoke detectors and hard contact detectors in electronic bases, where these are not used with external (remote) LED indicators.

Where other types of detector are used, or detectors are used to switch remote LED indicators directly so that the alarm voltage is out of the B2 range (approx. 3V-13V), the circuit will have to be programmed accordingly. In some cases constraints are also applied to zone programming. For example, where a non-latching detector (e.g. Olsen P76B) is used for air duct sampling, then as well as programming the circuit for the appropriate RAD or SAD time delay sequence, the zone should be programmed as non-latching.

2. ALARM TEXT

Choose the appropriate text for each detector type e.g. smoke (default) for smoke detectors, heat for thermal detectors, etc. There is provision for creating new names if the standard ones are not sufficient.

The Instant Alarm text may also be changed if required (default is manual).

3. MODE

Mode 1 (standard) suits most detectors where remote LEDs are not used.

High Current Detectors

The following detectors require the F3200 circuit to be programmed into high current mode (mode 2) to give sufficient LED (lamp) illumination current.

Olsen C23B, C23BEx, R23B, R24B (and Ex where applicable), Flameguard, Intertec, Apollo Series 60.

APPENDIX A2 (CONTINUED)

Remote LEDs

Where remote LEDs are used, mode 2 may have to be selected to give sufficient current for illumination, depending on the particular LED kit used.

Where mode 2 is selected, some detectors require voltage band B3 to be programmed as Alarm. See tables I-V.

4. DELAY TYPE

Delay types 2 and 3 with a delay out of alarm (Delay 2 greater than 0) require a non-latching detector (e.g. Olsen P76B).

5. VOLTAGE BANDS

The following tables I-V show the expected alarm voltage band for each type of detector in Mode 1 (standard) and Mode 2 (high current). A “-“ means there is no need to use Mode 2 (and it should not be used).

Where a value other than B2 is shown (e.g. B1 or B3), then that voltage band must be programmed as Alarm, as well as B2.

Hard Contact Detectors

Hard contact detectors that are not fitted to an electronic base may also be connected directly across the circuit. Program the detector type as appropriate (e.g. heat, flowswitch) and voltage band B1 as Alarm (detector operated).

If detectors and MCPs are to be used on the same circuit, with differentiation between them (e.g. for AVF), then it is necessary to use 15V MCPs and program B3 = Instant Alarm. This means that 15V MCPs cannot be used on the same circuit as any detector that requires B3 = Alarm.

DETECTORS COMPATIBLE WITH F3200 FIP		VOLTAGE BANDS FOR MODES 1 & 2	
TYPE	DESCRIPTION	MODE 1	MODE 2
DCD-A	(DCA-B-60R & DCC-A) HEAT DETECTOR TYPE A	B2	B3
DCD-C	(DCA-B-90R & DCC-C) HEAT DETECTOR TYPE C	B2	B3
DFJ-60B	(DFB-60B & DFE-60B) HEAT DETECTOR TYPE B	B2	B3
DFJ-90D	(DFB-90D & DFE-90D) HEAT DETECTOR TYPE D	B2	B3
SIJ-ASN	(SIF-A & SIH-AM) IONISATION SMOKE DETECTOR	B2	B3
SLR-AS	(SLK-A & SLG-AM) PHOTOELECTRIC SMOKE DETECTOR	B2	B3
HF-24A	ULTRAVIOLET FLAME DETECTOR	B2	B3

Table I
HOCHIKI Detector Range

DETECTORS COMPATIBLE WITH F3200 FIP		VOLTAGE BAND FOR MODES 1&2	
TYPE	DESCRIPTION	MODE 1	MODE 2
MD614A	HEAT DETECTOR TYPE A	B2	-
MD614C	HEAT DETECTOR TYPE C	B2	-
MF614	IONISATION SMOKE DETECTOR	B2	-
MR614	PHOTOELECTRIC SMOKE DETECTOR	B2	-
MR614T	HIGH PERFORMANCE OPTICAL SMOKE DETECTOR	B2	-
MU614	CARBON MONOXIDE DETECTOR	B2	-
T614A	HEAT DETECTOR TYPE A	B2	-
T614B	HEAT DETECTOR TYPE B	B2	-
T614C	HEAT DETECTOR TYPE C	B2	-
T614D	HEAT DETECTOR TYPE D	B2	-
MS302Ex	INFRA-RED FLAME DETECTOR	B2	-
S111	INFRA-RED FLAME DETECTORS (IS)	B2	-
S121	INFRA-RED FLAME DETECTORS (IS)	B2	-
S131	INFRA-RED FLAME DETECTORS (IS)	B2	-
S231i+/f+	INFRA-RED FLAME DETECTOR (IS) (Refer 6.6.1)	B2	-
S261f+	INFRA-RED FLAME DETECTOR	B1	-
MF301Ex	IONISATION SMOKE DETECTOR	B2	-
MR301Ex	PHOTOELECTRIC SMOKE DETECTOR	B2	-
MR301TEx	HIGH PERFORMANCE OPTICAL SMOKE DETECTOR	B2	-

Table II
Tyco Detectors

DETECTORS COMPATIBLE WITH F3200 FIP		VOLTAGE BAND FOR MODES 1&2	
TYPE	DESCRIPTION	MODE 1	MODE 2
4098-9618EA	HEAT DETECTOR - TYPE A	B2	-
4098-9619EA	HEAT DETECTOR - TYPE B	B2	-
4098-9621EA	HEAT DETECTOR - TYPE D	B2	-
4098-9603EA	IONISATION DETECTOR	B2	-
4098-9601EA	PHOTOELECTRIC DETECTOR	B2	-

Table III
Simplex Detectors

DETECTORS CERTIFIED WITH F3200 FIP (SSL # 336)		VOLTAGE BANDS FOR MODES 1 & 2	
TYPE	DESCRIPTION	MODE 1	MODE 2
B111B	BEAM TYPE SMOKE DETECTOR SEE NOTE 1	B1	-
B21B	BEAM TYPE SMOKE DETECTOR	B3	-
C23B	IONISATION SMOKE DETECTOR SEE NOTE 3	B2 *	B3
C23BEx	IONISATION SMOKE DETECTOR SEE NOTE 3	B2 *	B3
C24B	IONISATION SMOKE DETECTOR	B2	B2
C29B	IONISATION SMOKE DETECTOR	B2	B2
C29BEX	IONISATION SMOKE DETECTOR (IS)	B2 *	B2
DLO1191A	BEAM SMOKE DETECTOR	B3	B3
FW81B	HEAT DETECTOR CABLE FW68, FW105 (IS)	B1, B2	-
P24B	PHOTOELECTRIC SMOKE DETECTOR	B2	B2
P29B	PHOTOELECTRIC SMOKE DETECTOR	B2	B2
P61B	PHOTOELECTRIC SMOKE DETECTOR (REV J)	B2	-
P76B	PHOTOELECTRIC SMOKE DETECTOR (NOTE 2)	B3	B3
P136	PHOTOELECTRIC SMOKE DETECTOR (NOTE 2)	B2	-
R23B	INFRARED FLAME DETECTOR	B2 *	B2
R24B	DUAL SPECTRUM INFRARED FLAME DETECTOR	B2 *	B3
R24BEX	DUAL SPECTRUM INFRARED FLAME DETECTOR (IS)	B2 *	B3
T54B	PROBE TYPE E HEAT DETECTOR (IS OR FLAMEPROOF)	B1	-
T56B	HEAT DETECTOR TYPES A, B, C, D (IS WITH Z55 BASE) SEE NOTE 1	B2	B2
V41B	ULTRAVIOLET FLAME DETECTOR SEE NOTE 1	B1	-
V42B	ULTRAVIOLET FLAME DETECTOR SLAVE	-	-
V44B	ULTRAVIOLET FLAME DETECTOR SEE NOTE 1	B1	-
SU0600	15V MCP	B3	B3
DETECTORS WITH BASES AS APPLICABLE			

Table IV
Tyco Detector Range

DETECTORS CERTIFIED WITH F3200 FIP (SSL # 336)		VOLTAGE BANDS FOR MODES 1 & 2	
TYPE	DESCRIPTION	MODE 1	MODE 2
SERIES 60	APOLLO HEAT DETECTOR TYPES A, B, C, D	B2 *	B3
SERIES 60	APOLLO PHOTOELECTRIC SMOKE DETECTOR	B2 *	B3
SERIES 60	APOLLO IONISATION SMOKE DETECTOR	B2 *	B3
ALL WITH 45681-200 BASES			
MKVIII	FLAMEGUARD HEAT DETECTOR TYPE A, 24V	- *	B3
MKVIII	FLAMEGUARD HEAT DETECTOR TYPE C, 24V	- *	B3
MK5, MK6	INTERTEC HEAT DETECTOR TYPES A,B,C,D	B2 *	B2
ZAU401	ZONE ADAPTOR UNIT (REV 2)	B2	B2

**Table V
 Other Detectors**

Notes

1. Hard contact devices without "electronic" bases give voltage band B1 unless a 6V8 zener diode is wired in series with the contacts which gives B2 alarm.
2. The P76B requires band B3 to be programmed as Alarm (detector operated) though typical operation for both modes 1 and 2 will give B2 voltage (just less than 12V).

For non-latching operation the zone must be programmed as non-latching.
3. The C23B and C23BEx (old types of detectors) may have a nominal 6V/30mA bulb in them which require Mode 2 for illumination. The bulbs may have been replaced with LEDs. Although the bulb would typically give B2 operation, it is safest to program B3 as Alarm. The R23B with an LED needs only B2 in Mode 2. (Note that the incandescent lamps do not meet the SSL005 Standard).
4. Detectors shown with an "*" need to be programmed for Mode 2 to give sufficient lamp illumination. The Flameguard detectors require Mode 2 for latching and require an extra resistor (270E, 5W) to be switched in from +VBF to the AZC+ terminal for LED illumination. If relay n is used to boost AZCm, the logic for the relay is $R_n = Z_m A.^{\wedge} Z_m R$.
5. For IS applications refer to Section 6.4.

WARNING

Detectors which require voltage band B3 to be programmed as Alarm (detector operated) cannot have an MCP with a 15V Zener Diode (e.g. SU0600) connected to the same circuit.