

INFORMATION SHEET

DESCRIPTION

- 801CHEx CO/Heat

The 801Ex range of Intrinsically Safe *MX* analogue fire detectors and callpoints are rated for installation in certain hazardous areas. They transmit digital values to compatible *MX* Control and Indicating Equipment (c.i.e.) to indicate the level of smoke/CO/heat/flame they are sensing. The c.i.e. determines the condition, alarm, fault, etc, and responds according to the detection mode selected in the site configuration.

By using dual sensors in the 801PHEx and 801CHEx a wider range of fire risks can be covered. The 801FEx is a single wavelength infrared flame detector that has an optical filter to reduce the effects of sun and artificial lighting. It has a range of up to 18m with a field view of 1100m² for a 0.4m² N-heptane pan fire. The CP840Ex is an I.S. manual call point and in addition the IF800 I.S. Input Module is available for interfacing to a clean contact device within the hazardous areas. For use in hazardous areas the standard *MX* loop voltage must be reduced and isolated. This is achieved by using an EXI800 I.S. Interface Module and a P&F KFDO-CS-Ex 1.54 Isolator to connect each spur of *MX* I.S. devices onto the *MX* Loop.



There are limits to the IS spur loading and *MX* loop design so refer to the relevant *MX* c.i.e design manuals. All detectors must be used with the 5BEx base in hazardous areas.

SPECIFICATIONS	801PHEx	801CHEx	801FEx	801HEx	CP840Ex
(less base)	Photoelectric/Heat	CO/Heat	Flame	Heat	Call Point
Height	43mm	43mm	43mm	43mm	59mm
Diameter	108mm	108mm	108mm	108mm	124mm
Weight	126g	126g	110g	120g	340g
Loop Voltage	18V to 24Vdc addressable loop voltage is provided by the EXI800				
Quiescent Current (typical)	350µA	300µA	300µA	280µA	250µA
Alarm Current	3mA	3mA	3mA	3mA	4.5mA
Max. Detectors per Loop ¹	250	250	250	250	250
Ambient Temperature ²	-25°C to +70°C	0 to +55°C	-20°C to +70°C	-25°C to +70°C	-25°C to +70°C
Storage Temperature	-40°C to +80°C	-20°C to +55°C	-40°C to +80°C	-40°C to +80°C	-40°C to +70°C
Relative Humidity ³	95%	95%	90%	95%	95%
IECEX Certificate	BAS 07.0063X	BAS 07.0063X	BAS 07.0075X	BAS 07.0063X	BAS 07.0063X
Standards	EN54-5 EN54-7	EN54-5	EN54-10	EN54-5	EN54-11
Part Number	516.800.530	516.800.531	516.800.066	516.800.532	514.800.513

- MX* c.i.e. Refer to appropriate manual LT0360 (*MX 1-NZ*) LT0441 (*MX 1-Au*) for design specifications.
- Maximum ambient temperature depends on temperature threshold set for heat detector.
- Maximum, non condensing.

DETECTOR ADDRESS

The address label carrier is fitted to the detector before mounting on the base. When the detector is mounted to the base, and turned clockwise until fully located on the base, the address label carrier is transferred to the base. If the detector is removed the address label carrier remains on the base.

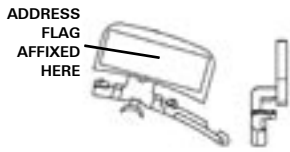

Part Number	Desc.
5 16.800.915	Label Carrier
5 16.800.931	White Label
5 16.800.932	Yellow Label
5 16.800.933	Purple Label
5 16.800.934	Green Label

LOCKING KEY

A detector locking device is moulded into the 5BEx base. This must be detached and inserted into the locking aperture if required, prior to the selected detector being installed. The detector may then be removed only by inserting an unlocking tool (a Ø3 x 22mm long rod) into the hole on the detector cover to depress the locking device. The part number for the locking device (pack of 100) is 5 17.050.005.



WIRING

All wiring terminates at the 5BEx base as follows:

L: – In and Out **L1:** + In, Out

Cables should be arranged at each side of the terminal screw. A maximum of two 1.5mm² cables or one 2.5mm² cable can be fitted to one terminal. Any additional cables should be fitted with suitable fork or eyelet crimp terminal lugs. The installation should comply with AS 1670.1/NZS 45 12 and AS/NZS 2381.

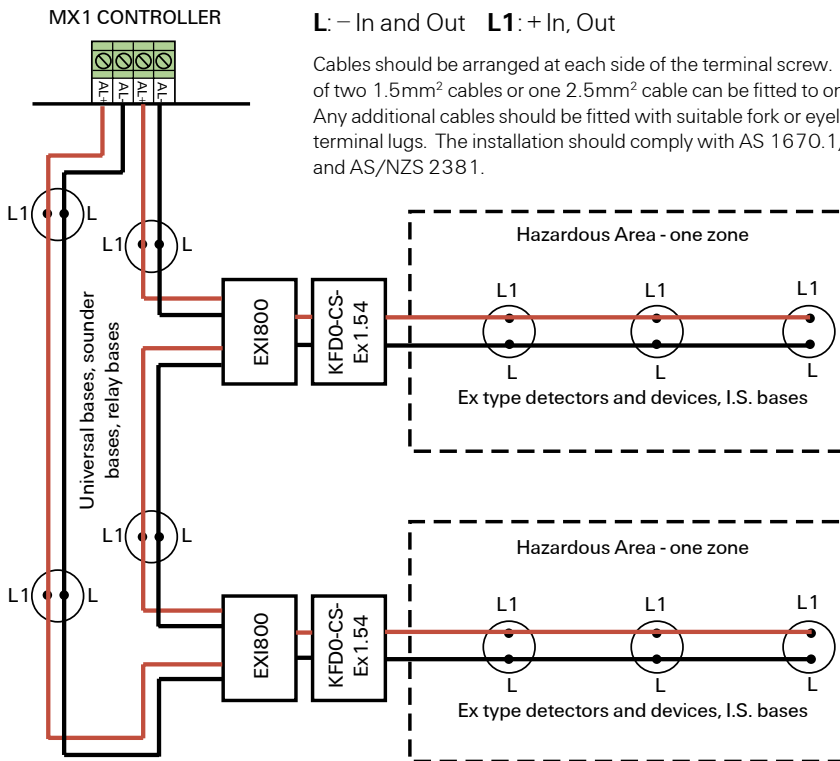

DETECTOR IDENTIFICATION

Each detector is identified by a unique label on the top, as shown:

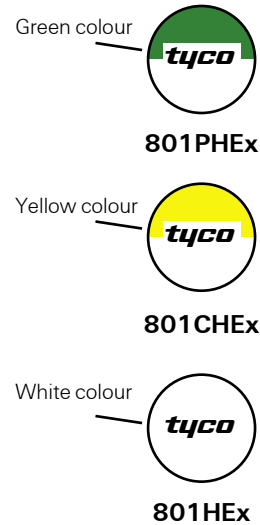

INSTALLATION

The 801Ex series of detectors are not suitable for use where they may be exposed to condensing moisture, mist or water spray.

When mounting on a damp surface or narrow beams where condensation may enter the rear of the detector, the deckhead mounting base DHM5B (part no. 5 17.050.603) or similar should be used. The 801CHEX should not be positioned where high localised levels of CO may normally occur, e.g. indoor car parks, warehouses. The 801HEX Heat detector may be more appropriate. Installation of all detectors should be carried out in accordance with AS 1670.1/NZS 45 12 and hazardous area installation requirements (e.g. AS/NZS 2381). Cable penetrations should be sealed when positive or negative pressures in ceiling spaces may affect the performance or contaminate the installed detectors.

MAINTENANCE AND SERVICE

The Tyco MX addressable system should be maintained in accordance with AS 1851/NZS 45 12. The Tyco X300 Smoke Tester, X461 Heat Tester and CO Test Gas (part no. 5 17.001.262) may be used for testing *in-situ*. Rotating the detector anticlockwise past an indent to the **park** position disconnects the detector from the circuit whilst still retaining it in the base, allowing wiring testing etc. Note that insulation testing must not be done when isolator bases are used.

Depressing the plunger at the side of the base allows the detector to be rotated back into its operating position. Wormald Detector Clean & Calibrate Wollongong are able to check the calibration of MX detectors. Additionally, although the 801CHEX has an expected life in excess of 10 years, in order for the 801CHEX to provide the intended level of fire detection, the detector should be checked for calibration 5 years after installation or within 7 years of the date of manufacture.

Applications Warning In many fires, hazardous levels of smoke and toxic gas can build up before a heat detection device will initiate an alarm. In cases where life safety is a factor, the use of smoke and/or CO detection is highly recommended. Heat detectors are not considered to provide life safety protection and are generally used where property protection is desired, but smoke or CO detectors cannot be used. Typical heat detector applications are satisfied by the use of rate-of-rise and fixed temperature electronic detectors. The addition of rate-of-rise operation provides faster heat detection for use where temperature fluctuations are controlled and less than 6°C/min. Where temperatures may fluctuate more quickly, use fixed temperature detection only.